

---

# THE UNIVERSITY OF AKRON

## NFPA Fluid Power Vehicle

### Challenge

### Project Report

---



4/14/2017

**The University of Akron**  
302 E Buchtel Ave  
Akron, OH, 44325

Submitted by: *Ean Dickerhoof*  
*Ben Adkins*  
*Matt Warner*  
*Jeff Smith*  
*Joshua Phillips*

Advisor: *Dr. Scott Sawyer, Associate Professor, and*  
*Associate Chair for Undergraduate programs*  
*Dr. Celal Batur, Professor*

## TABLE OF CONTENTS

1.0	ABSTRACT OR EXECUTIVE SUMMARY.....	2
2.0	PROBLEM STATEMENT.....	3
3.0	PROJECT PLAN /OBJECTIVES (include info on classroom support).....	3
4.0	DESIGN .....	6
5.0	DESIGN DRAWINGS.....	10
6.0	COMPONENT LIST.....	13
7.0	ACTUAL TEST DATA COMPARED TO ANALYSIS.....	16
8.0	COST ANALYSIS.....	21
9.0	LESSONS LEARNED.....	22
10.0	CONCLUSIONS.....	23
11.0	APPENDIX A - CAD MODEL DRAWINGS.....	23
12.0	APPENDIX B - Preliminary Calculations.....	27
13.0	APPENDIX C - Component Drawings.....	30

## 1.0 EXECUTIVE SUMMARY

Every year the National Fluid Power Association hosts a Fluid Powered Vehicle Challenge, this exposes students from universities all around the United States to the power and possibilities of hydraulics. This year the University of Akron's team of engineers set out to design a bicycle that would be competitive and innovative in all aspects of the competition. In order to accomplish this, the designed bicycle must excel in three categories of competition; a sprint race, an endurance race, and an efficiency challenge.

To accomplish this task the University of Akron's team of engineers used a lightweight bicycle frame with many key hydraulic components mounted to it. An Eaton 26 series pump and motor served to power the direct drive side of the bicycle that will be used to compete in both the sprint and endurance races. A Parker F-11 high pressure motor and Eaton Vickers accumulator served to power the accumulation side of the hydraulic circuit through charging and discharging. These accumulation components are used in the efficiency challenge and are controlled by a Eaton four way three position rotary valve that determines when energy is being stored and when energy is being released. Lightweight bicycle components as well as a broad range of gearing selection will allow for competitive advantages for all three events of the Fluid Powered Vehicle Challenge.

The final product is a spectacle, one that pushes the limits of what was previously possible at the University of Akron. Precisely machined to allow for high speeds of fifteen miles per hour and long accumulation distances more than three hundred feet in length. All of this and more at a cost less than five thousand dollars. With this product the University is set-up to succeed and compete with an innovative design at the 2017 National Fluid Power Association Fluid Powered Vehicle Challenge.

## 2.0 PROBLEM STATEMENT

Engineers are always looking to change or improve the way tasks are completed. The NFPA created the Fluid Powered Vehicle Challenge to test the way a bicycle is powered. Typically, bicycles use chains in order to transform human movement to movement of the bicycle. For this challenge, the goal is to design, test, and build a human powered bicycle of a maximum 210 lbs, using hydraulic fluid as its source for power transfer. The main objective for the NFPA sponsored event is to familiarize and become educated with hydraulics, pneumatics, and other energy devices in order to make the best bicycle possible. This knowledge will then be used to create a bicycle that will not only drive with the direct interaction of a human, but also have the capability to store energy to propel the bicycle at any given time, specifically from stop. With these two means of propulsion, there are three events the bicycle must complete. The first event is a sprint race of 600 ft. This event will prove that the bicycle is direct drive can reach high speeds. The second event is the efficiency challenge. This event will demonstrate the ability of the vehicle to build and use stored energy to propel itself a distance beyond 100 ft. The third and final event is the 1 mile reliability/durability challenge. This event will demonstrate the reliability, safety, and durability of our bicycle.

### 3.0 PROJECT PLAN /OBJECTIVES

The main objective for this year's Fluid Power Vehicle Challenge involved getting The University of Akron's team back to being competitive and innovative in both performance and design. In the past, the University of Akron's teams have performed well, however in recent years the results have been lacking. Because of this, the 2017 Fluid Power Vehicle Challenge Team decided on a complete redesign from last year's tricycle. At the onset of the project, the team set up and rode the previous year's tricycle. Quickly, many disadvantages were noted;

- Weight and Size: The tricycle design made the bicycle very heavy, which only increases the torque needed from the rider and the motor. The new design aimed to revert back to using an original two wheel bicycle frame, this would instantly decrease weight which would decrease the amount of pressure and size of the accumulator that would be needed. Using a bicycle will also provide the maneuverability that was lost with the tricycle.
- Pedaling Freedom: Difficulty arises on a hydraulic bicycle when attempting to link pedaling to a hydraulic system because of the space that is provided on a traditional bike compared to the size of hydraulic components. Last year's bicycle had an extended crank that widened the area for the pump to connect to the pedal stroke which created a very unnatural pedaling stroke and some interference with the hydraulic lines. To combat

these characteristics, machining techniques and fittings will be used allowing hydraulic lines to be clear from the natural pedal stroke.



**Photo 1: University of Akron's 2016 hydraulic tricycle**

- Complexity and Abundance of Hydraulic lines: Relevant coursework shows that longer hydraulic lines have more losses developed. To mitigate these losses, the length of the lines can be reduced by the placement of key components and check valves to direct the flow in the hydraulic system.
- No Coasting: Due to the way the hydraulic components were attached to the rear drive, once the rider stopped pedaling with speed, the rear pump would continue to turn and release pressure from the system which would eventually create a braking force. Designing a bicycle that has a coasting feature was a primary design requirement in order to efficiently use the energy provided by the rider.
- Difficult Gearing (non-direct): Riding a chained bicycle for years develops a habit and expectation that making turns of the pedals should translate directly to a force that would be applied directly to the back wheel. However, upon riding the 2016 bike, the sensation was far from that. Pressure was needed to be built up from multiple revolutions then released in a quick burst of torque. Therefore, the objective is to design a hydraulic bike that feels like the direct drive of a chain bicycle. In order to accomplish this, gearing techniques and drive circuits were experimented with.

Being able to ride last year's bicycle proved to be very valuable. A list of key design objectives for this year's bicycle were created that will contribute to the goal of designing an innovative and competitive fluid power vehicle for competition.

#### OBJECTIVE 1: LIGHTWEIGHT

Keeping the total bicycle weight minimal allowed for so many advantages and helped solve the disadvantages from the previous year's model. The main constant involved in a bicycle is the rider's input. Whether the bicycle weighs two-hundred pounds or fifty pounds, the power input from the rider remains constant. This is also true for the accumulation hydraulic circuit. A heavier bicycle would require a larger force to propel the system forward. However, a prolonged large force would require a large accumulator, which increases the weight. Therefore it was pertinent that the 2017 bicycle remained as light as possible.

#### OBJECTIVE 2: SIMPLISTIC DESIGN / EASE OF USE

In real world applications, simplicity of the design and ease of use can make or break a product's potential in the market. A design that potential users could follow and do maintenance on themselves would be beneficial in the market place. In the hydraulic bicycle's case, a simplistic design would allow for easy setup, troubleshooting, and maintenance, which could increase overall bicycle performance.

#### OBJECTIVE 3: DIRECT-DRIVE CIRCUIT

Replacing a chain on the bicycle isn't an easy task. The chain delivers power and torque immediately from one rotational element to another, and with the elimination of a chain, power must be transmitted some other way. In order to create a riding experience that feels as natural as a chained bicycle, rotation of the pedals needs to be transferred to the back wheel quickly and efficiently. Successfully doing this would be know as a direct drive cycle.

#### OBJECTIVE 4: REDUCE FRICTION / ALLOW FOR COASTING

A traditional bicycle accomplishes this by allowing the rear cassette of gears to operate on a free-wheel that allows torque to be applied in one direction only, and induces the separate application of brakes for slowing down. In order to accomplish the coasting effect, a one directional motor must be used or a free wheeled attachment hub on the rear wheel. These steps would assure that not pedaling the bicycle would have no negative effects other than the rotational frictional forces that eventually bringing the bicycle to a stop. Friction is the next killer of efficiency, but is greatly reduced by using 2 wheels instead of 3. And it is further reduced by having the smallest contact area possible with the ground, that means skinny tires and lots of tire pressure.

OBJECTIVE 5: SAFETY

Working with hydraulic fluids there are serious dangers, and precautions need to be taken in order to insure safety among team members and surrounding individuals. To do this, placement of pressure gauges within the circuits will be used to assure that the operational pressure is within the safety factor of the hoses and motors. The correct fittings at connection point should also be used so that no hydraulic fluid leaks. Traditional bicycle safety requirements such as closed toed shoes, long pants, and safety helmet will also be observed.

**4.0 DESIGN**

Once a generic idea of the bicycle was created, the team went through a preliminary design process for selecting components that can be seen in Appendix B. These equations and results allowed for accurate selection of components, and allowed for the design and manufacturing process to begin. The use of the 8 speed Shimano hub was definitely going to be used, so the manufacturing process began with gears. The gears on the bike are all Martin Sprocket steel spur gears with sixteen degree pitch and pressure angle of fourteen and a half degrees. The thickness of the gears are half inch which is more than sufficient for transmitting human pedal power yet retains excellent mesh. Through basic calculations given below, excel was programed with the equations (Table 1) and was used to decide what gear ratios and gears to buy. After bench testing, a pedal speed of eighty revolutions per minute was used to determine the gear ratios. The objective when deciding on the gearing ratios was based also on the assumption that one revolution of the pump would initiate one revolution of the motor due to similar volumetric flow rates.

$$\text{Gear Ratio} = (\text{Crank Gear}/\text{Pump Gear}) * (\text{Drive Gear}/\text{Axle Gear})$$

$$\text{Pump (rev/min)} = \text{Crank Gear}/\text{Pump Gear} * \text{Pedal input}$$

$$\text{Speed (mph)} = \text{Gear Ratio} * \text{Pedal Input} * \pi * \text{Wheel Dia.} * 9.4589 * 10^{-4}$$

Direct Drive Gearing	Teeth	Outputs	
Crank	96	Ratio	2.4
Crank-pump	28	Pump (rev/min)	274.3
Pump-drive	28	Wheel (rev/min)	192
Drive	40	Distance covered (ft/min)	1306.9
Input Pedal (rev/min)	80	Speed (mph)	14.8
Wheel diameter (in)	26		

**Table 1: Gearing Calculations**

Machining and modification of gears-

In order to attach the gears to the rear hub, machining was required. The Shimano Alfine rear hub has a freewheel side, where the bike will coast going forward, and a spline on the other side. With the drive circuit, the ability to coast is necessary so the freewheel side of the hub is used. The hub requires a three pronged key-way design in order to fasten the gear to the hub. A bike sprocket was purchased and then machined to be welded to our gear.



**Photo 2: Drive side Gear - Machine to Weld**

From the above process chain, one can see the gear had to be bored out, counterbored and faced to fit perfectly onto the hub. The three pronged key-way piece cut from the bike sprocket was welded to the machined forty tooth gear. This gear is held in place by a snap ring and fits securely between the hub and the rear shifting mechanism.



**Photo 3: Hub Assembly**

The above hub assembly depicts the gear on the regeneration side of the hub, which needed to be bored and counterbored to fit on the hub. The Shimano disc brake adaptor allowed the gear to be attached to the hub.



The next obstacle to tackle is how to attach a gear to the pedal crank. Different options were to extend the crank axle and attach the gear on the axle. This would require removing the axle and extending the natural placement of the pedals. Instead it was decided to mount the gear on the crank arm in place of where a traditional bike sprocket goes.



**Photo 4: Crank and gear assembly**

The gear was bored out to the exact size of the crank arm which allowed it to self center. Holes were drilled and tapped to bolt the gear to the crank arm. The aluminum crank arm needed to be grinded, which can be observed in Photo 4 in order for the gear to sit flat. This design sheds unnecessary weight in the middle of the gear making our gear light while not sacrificing strength. The slim fit also retains the natural pedaling geometry that helps to promote our simplistic and lightweighting objectives.

Hydraulic Circuit Design-

The accumulation circuit has three settings that are all determined by the four way three position manual rotary valve. Each of these setting are as described below referencing Circuit Diagram 1.

Setting 1: Charging

In setting one the rotary dial is turned to the left allowing hydraulic fluid to be pulled from the large reservoir through the Parker F-11 motor on attached to the rear wheel into the accumulator. This cycle continues until there is either no fluid left in the reservoir or the accumulator reaches max pressure or volume. Our design assures that there is sufficient hydraulic fluid in the reservoir from the onset, therefore the limiting factor to this is the space and pressure in the accumulator which is determined by a pressure gauge located between the accumulator and the valve.

Setting 2: Bypass

When the valve is in the middle position the system is in bypass mode which blocks off the reservoir and the accumulator and just allows the fluid caught in system to be pumped in a circle. This setting is used when the accumulator is not in use, and the bicycle is being driven by the direct drive system.

Setting 3: Discharging

When the valve is in the right position the system is in discharge, this is where the stored energy of the accumulator is allowed to exit and power the rear wheel. The pressurized fluid exits the accumulator, flows through the valve and enters the Parker F11 motor, then returns to the reservoir unpressurized. Once the system is discharged the valve can be turned back to the bypass setting for normal riding conditions.

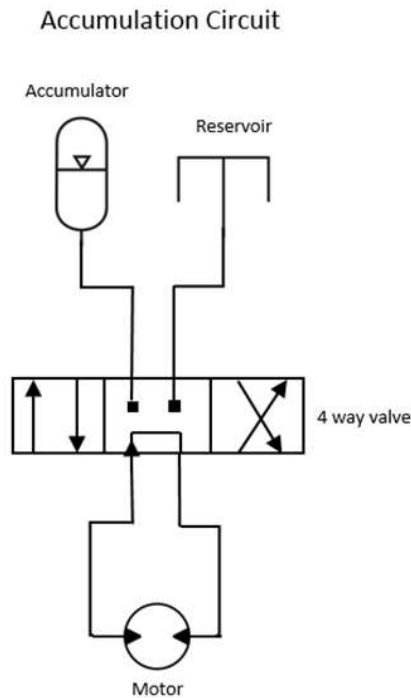

**Circuit Diagram 1: Accumulation Circuit**

Direct Drive Circuit

The direct drive circuit which can be seen in Circuit Diagram 2 only has one setting because it is the main power source for the bike. A smaller reservoir that is attached to the low pressure return line of the circuit is used to bleed the system of air. Once the system is completely bled the ball valve can be switched off to block the reservoir from the system. Allowing minimal resistance when coasting out from the initial propulsion.

Direct Drive Circuit

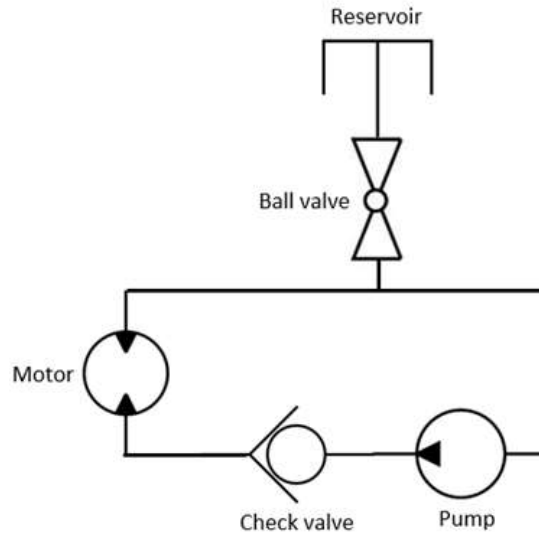

**Circuit Diagram 2: Direct Drive Circuit**

**5.0 DESIGN DRAWINGS**

The gears used on the bicycle attached to the pump, motors, hub, and crankset needed modification to fit the requirements of the design. Martin Spur gears were purchased and modified to suit. The following engineering drawings reflect the changes made to the gears.

Drive Gear Crank - Martin Spur Gear Machined - Part No: *S1696*

Martin spur gears are manufactured from cast iron to provide the strength need to withstand the torque need from larger machinery, this makes the gear bulky and heavy for a bicycle application where the torque is only created by the power of a human. Boring the majority of the crank gear out in order to fit a normal pedal crank mount. This allowed for a simplistic look, and a lighter bicycle while maintaining the higher gear ratio that was need for efficient operation of the pump.

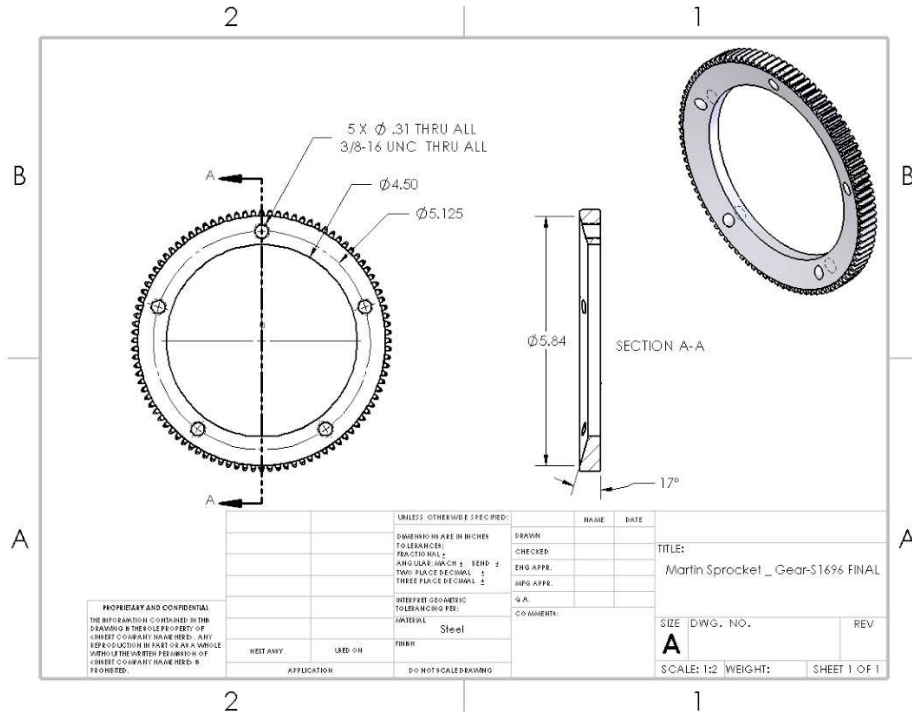

Drawing 1: Crank Gear

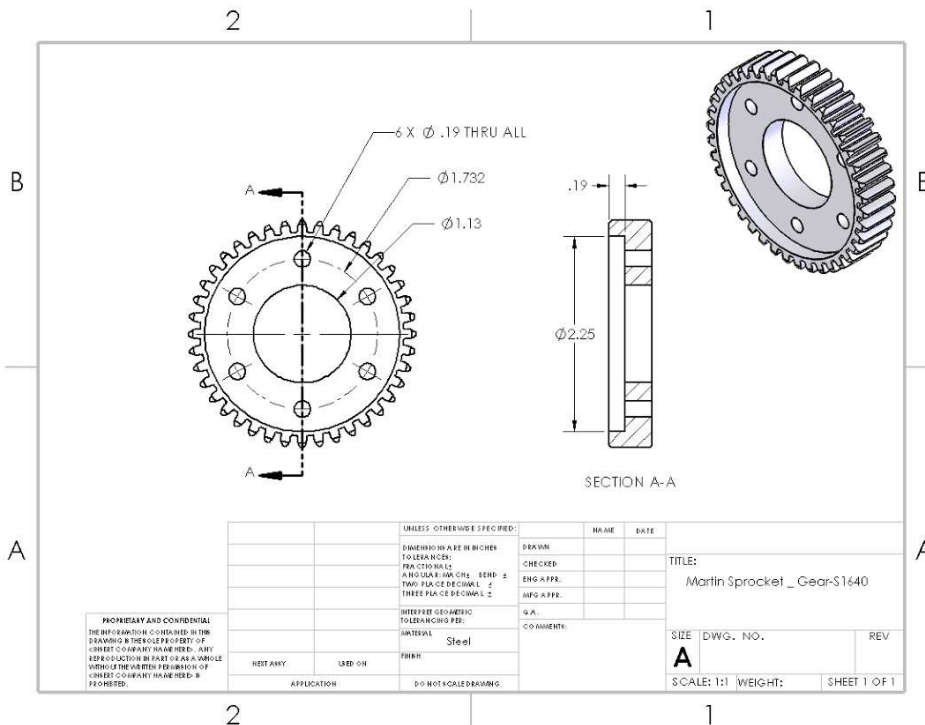

Drawing 2: Accumulation Gear

Accumulation Gear Hub - Martin Spur Gear Machined - Part No: S1640

To complete the hydraulic circuit our team of engineers need to design a gear the could be attached to the opposite side of the hub and be driven in both directions. Due in part of our hub selection a disc brake attachment was used to connect the machined gear onto the hub. This allows for a stable foundation for the accumulation circuit to be both driven and charged by the connection point on the hub.

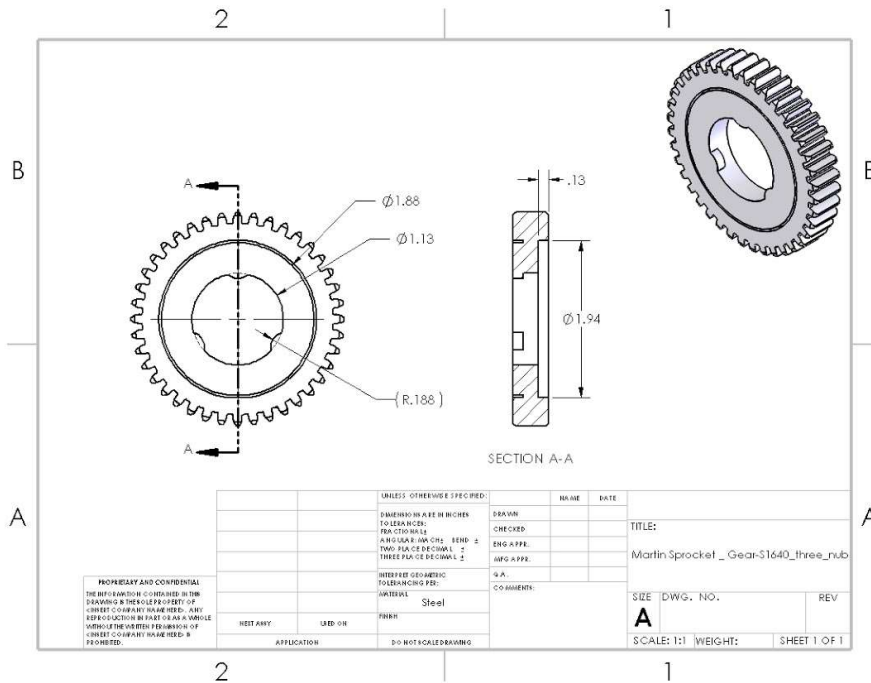

**Drawing 3: Direct Drive Gear**

Drive Gear Hub - Martin Spur Gear Machined - Part No: S1640

The challenge with this spur gear application was not the weight, but more so how to fit the gear on to the freewheel side of the hub. Due to the fact that machine the three pronged key-way would have required precise machining, the team developed an alternative solution by boring out the gear, and then welding on an existing key-way. This allowed for a tight fit to the hub which improved safety by protecting the gear. From the externals of the bicycle.

All other drawings made for this project were of parts not modified specifically for this application and as such are less pertinent for this report. All of the drawings can be found in Appendix A.

## 6.0 COMPONENT LIST

The University of Akron has competed in this competition for the last several years. In coordination with Parker Hannifin a room in the University of Akron’s Auburn Science and Engineering Center is used for storage, testing, and manufacturing of the bicycle. At the onset of the project, each team member spent time becoming familiar with the hydraulic components that already existed at the university, and then evolved into decisions on what would need to be bought and what components could be reused from previous years. Table 2 represents the list of bicycle components that were used for the 2017 bicycle design.

Bicycle Components	Quantity
Surly Bike Frame	1
Handle bar assembly	1
Shimano crankset	1
Bike seat and post	1
Rear Shimano Alfine 8 Speed gear hub	1
Brake assembly	2
Brake levers set	1
8 Speed Shift kit	1
Bike Computer	1

**Table 2: Bicycle Components**

The Surly bicycle frame used was repurposed from a previous team, as well as handle bars, seat, and crankset. Also previously purchased by a team in the past was a Shimano Alfine 8 speed internal gear hub. This was mounted on a rear wheel, and was used along with a matching front wheel, both found in the team’s inventory. The rims are 26 inches that are fit with skinny rubber tires. This is ideal because the road bike tires can be inflated to a high pressure, resulting in minimal rolling resistance due to the decrease in the contact patch with the rolling surface. Also used were the front brakes off of last years bicycle, but a new set of rear brakes were purchased along with a new set of brake levers. It was important to have both front and rear brakes due to the additional weight of hydraulic components to make the bicycle safe and able to stop over a short distance. With the internal gear hub, it was important to purchase a twist shifter, which mounts on the handlebars, to use the full potential of the hub. Lastly, a bicycle computer was purchased to display the speed and record the distance of the bicycle while riding and testing.

Hydraulic Components	Quantity
Eaton 26 Series Pump	1
Eaton 26 Series Motor	1
Parker F-11 Motor	1
Eaton Vickers Accumulator (1 liter)	1
Eaton Vickers 3 Position 4 way valve	1
Martin Crank spur gear (S1696)	1
Martin Pump spur gear (S1628BS) 3/4 inch	1
Martin Motor spur gear (S1628BS) 5/8 inch	1
Rear hub gears - Martin (S1640)	2
Parker Brass Check Valve	1
Reservoir kit	1
Water bottle	1
Button head Stainless Steel Screws (10)	1
Shimano 6 bolt disc brake Adaptor	1
Shimano sprocket wheel	1
Parker hydraulic hose assembly	4
Parker 6 R6X-S (swivel nut tee)	1
Parker 6-6 F6X-S (swivel 37 deg NPTF)	1
Parker 6-6 FTX-S (male connector)	1
Parker 8-12 C5OX-S (straight thread elbow)	3
Parker 30682-6-6b (82-F-S-JIC fitting)	1
Parker 801-6-BLK-RL (3/8 BLK hose)	2
Hose clamps	4
Parker 3/8 x 1/4 FF-S (Pipe Nipple)	1
Parker MV609-6 (Female valve)	1
Parker 8-10 F5OX-S (Straight)	2
Parker 12-16 F5OX-S (straight)	1
Parker 12-8 TRTX-S (Reducer)	1
Parker 12 BTX-S (Nut)	1
Parker 6 F5OX-S (Straight)	2
Parker 6 C5OX-S (Elbow)	2

**Table 3: Hydraulic Components**

KEY HYDRAULIC / MACHINED COMPONENT BREAKDOWN -

Drive Pump - Eaton 26 Series Pump- Part No: *ACN-A-R-02-AC-A-0-01-00-00-0-00-00-0-A*

Drive Motor - Eaton 26 Series Motor - Part No: *ADM-A-D-02-AM-A-01-00-0-00-0-00-00-0-A*

This series of pumps and motors are made from an aluminum die casting and are formed to offer rigid structure in a limited space. Classified as a gear pump the 26 series uses a 13-tooth high efficiency gear profile that allows for 8.2 cu.cm./rev displacement and a maximum pressure of 3500 psi, whereas the motor allowed for 8.8 cu.cm./rev displacement. These characteristic help to solve the project objectives by providing a lightweight yet rigid pump all in a compact assembly that allowed for pump placement in a natural position under the crank without having to extend the crank arm. The pressure rating falls above the required pressure for normal operation of the direct drive system for both the pump and the motor. The pump and motor combination are also very similar in displacement volumes per revolution, this characteristic was chosen to provide a one to one input to output feel, which when combined with gearing practice would allow for direct drive objectives.



Accumulation Motor - Parker F11 Series - Part No: *F11-005-HU-CV-K-000-000-0*

The Parker F11 motor is a high pressure fixed displacement motor that has bi-directional capabilities. This motor operates at high pressures up to 6,000 psi with a piston pump design that allows for high torque at low start-up speeds similar to what is experienced in the bicycle application. The motor has minimal moving parts which helps the needed reliability of the accumulation cycle. Although this motor outweighs components that provided similar characteristics, the team decided on the F-11 due to its durability and the ease of access that allowed for testing to be conducted in many forms.



Accumulator - Eaton Vickers (1L) - Part No: *A2-30-B-06-BN-M-20*

This Eaton Vicker accumulator holds up to 1 L of hydraulic fluid and has a maximum pressure of 3000 psi. Typically bladder accumulators are lighter than piston accumulators and often have similar characteristics in pressure rating and



volume. This accumulator, like most, requires a pre-charge of nitrogen gas to help the rubber bladder, made from Buna-N (nitrile), pressurize and discharge fluid.

Valve - Eaton Manual Rotary - Part No: *MRV4-10-D-A6H-00*

This Semi rotary directional control valve is a 4 port 3 position valve that allows for connection to the accumulator, high pressure motor line, low pressure motor line, and hydraulic reservoir. This specific valve is rated for 3000 psi and has a rated flow of 11 Liters per/min which is well above what will be need for the bicycle application, but will serve to reduce friction in the valve. With this single valve being able to accomplish so much within the housing, the rotary valve helps support the simplicity of design and lightweighting objectives.

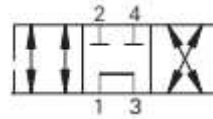

Some other miscellaneous components used to construct the bike are a small glass reservoir for bleeding the air out of the drive circuit. This replaced the makeshift plastic reservoir that was used in earlier testing. A brass Parker check valve, in the drive circuit, helps the pedaling of the bike feel more natural. Another Parker check valve is used in the regeneration circuit to keep flow directional. Various adaptors and hydraulic plumbing components were purchased from the Parker Store in order to connect our separate hydraulic circuits. The team decided to use a stainless steel 40 oz water bottle as the reservoir for the regeneration circuit. A hole was drilled in the cap of the water bottle and Parker  $\frac{3}{8}$  multipurpose hose is routed from the valve to the bottom of the bottle. Nuts and bolts on hand were used to fasten the different components to the bike. The only hardware purchased were the button head stainless steel screws for bolting our crank gear to the crank arm.

## 7.0 ACTUAL TEST DATA COMPARED TO ANALYSIS

Once the Eaton pump and motor were delivered, some base testing was conducted. A previous year's bike was modified to fit both a Parker F11 and Eaton 26 Series motor. The bike was tested with a Parker F11 on the front drive gear while changing/ comparing the rear mounted motors.

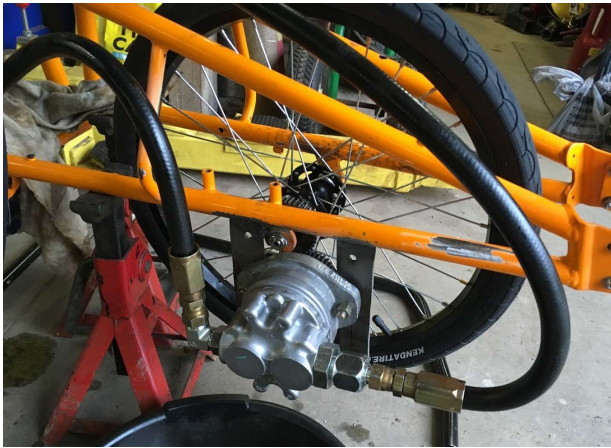

**Photo 5: Test Rig**

Photo 5 shows the Eaton 26 Series motor mounted to the back of the test bicycle while the the right shows the Parker F11 mounted to test bicycle. After testing, little to no difference in the Parker F11 and Eaton motor was found. This was pleasing to find this out as the Eaton pump and motor are much lighter and smaller than the Parker F11, so they would fit nicely on the smaller frame planned to use for the real build. Had this not been the case, the design would have had to be completely changed.

With the use of an Eaton 26 Series motor and pump, building on the new frame was a go. After machining gears to fit on a normal bicycle crank and an 8 speed rear hub, fabricating brackets to hold the pump and motor, and running lines from the pump to motor, the bicycle was ready for an initial test drive. At this point, there was a 96 tooth gear on the crank meshed with a 24 tooth gear on the front pump. This was linked to the rear motor and hub that both had 40 tooth gears. Our rear hub has 8 speeds and the ability to coast.



**Photo 6: Direct Drive Assembled on Final Frame**

After testing this bicycle, many improvements were seen from our original testing. With the rear hub, gears were able to be changed with increasing speeds and the bicycle could coast whenever needed. The lighter, smaller frame also made it very easy to ride. Unfortunately, there wasn't as much power generated from the rear wheel as desired. Although riding on uneven gravel, the bicycle had a top speed of about 9 mph and was geared too high. To improve on this, the gear on the front pump was changed from a 24 tooth gear to a 28 tooth gear, although a small change, this allowed the full range of the eight speed hub to be utilized. Also, when coasting and pedaling, back pressure was felt in the pedals and the pedaling was inconsistent. To fix this, a check valve was installed right after the outlet of the pump, limiting the fluid flow to one direction, making the pedaling more smooth and natural. The makeshift reservoir made it difficult, and unsafe to bleed the system. This would soon be replaced with a reservoir that could be open to atmospheric pressure safely so bleeding the system would be painless. Finally, the front tire would be replaced with a skinnier, less rolling resistant tire.

At this point, the assembly of the accumulation cycle was started. A gear was machined and a bracket was fabricated to mount a pump to fit on the rear hub. The general accumulation cycle was routed and attached to the accumulator and 3 position, 4 way valve.



**Photo 7: Accumulation Assembly**

The new improvements increased the bicycle's performance tremendously, and first test of the accumulation circuit was surprisingly very successful. The bicycle's max speed increased to 15 mph. With the new reservoir for the drive circuit, the circuit was able to be bled safely and efficiently. This reservoir setup also enabled the system to be completely closed off when desired. Unfortunately, the accumulator was unable to reach a pressure over 800 psi, but later found that the reservoir for the accumulation circuit was running dry. This limited the bicycle to a top speed of about 3mph with the accumulation circuit only. With that said, the size of the reservoir would soon be increased to a 40 oz bottle capable of holding just enough hydraulic fluid for our accumulator. The combination of fresh welds, old ripped decals, and some bare and unprimed components meant that the bicycle needed a fresh paint job.



**Photo 7: Finished Bicycle**

The increased capacity of our reservoir enabled the accumulator to reach pressures of about 1700 psi. Unfortunately, the small accumulator did not enable any more fluid to be pumped into it. With these pressures, the bicycle was still able to achieve a speed of 6mph from a dead stop using the accumulator only. Not only does the bicycle now run well, it also looks great with its fresh satin black paint with gold and silver accents. With the fresh paint job, the front and rear brakes were adjusted and permanently secured.

8.0 COST ANALYSIS

Description	Quantity	Cost
<b>Bicycle Components</b>		
Surly Karate Monkey Chubby bike frame	1	\$420.00
Handle bar Assembly	1	\$85.00
Shimano crankset	1	\$90.00
Bike seat and post	1	\$48.00
Rear Shimano Alfine 8 Speed gear hub	1	\$235.00
Brake assembly	2	\$28.00
Brake levers	1	\$19.00
8 Speed Shift kit	1	\$14.15
Bike Computer	1	\$31.49
<b>Hydraulic Components</b>		
Eaton 26 Series Pump	1	\$342.50
Eaton 26 Series Motor	1	\$487.00
Parker F11Motor	1	\$475.00
Eaton Vickers Accumulator	1	\$1,297.00
Eaton Vickers 3 Postion 4 way valve	1	\$205.46
Martin Crank spur gear (S1696)	1	\$88.70
Martin Pump spur gear (S1628BS) 3/4inch	1	\$47.95
Martin Motor spur gear (S1628BS) 5/8inch	1	\$47.95
Rear hub gears - Martin (S1640)	2	\$86.70
Parker Brass Check Valve	1	\$33.60
Reservoir kit	1	\$57.75
Water bottle	1	\$11.99
Button head Stainless Steel Screws (10)	1	\$11.07
Shimano 6 bolt disc brake Adaptor	1	\$15.99
Shimano sprocket wheel	1	\$5.00
Parker hydraulic hose assembly	4	\$62.50
Parker 6 R6X-S (swivel nut tee)	1	\$9.15

Parker 6-6 F6X-S (swivel 37 deg NPTF)	1	\$10.51
Parker 6-6 FTX-S (male connector)	1	\$1.61
Parker 8-12 C5OX-S (straight thread elbow)	3	\$41.85
Parker 30682-6-6b (82-F-S-JIC fitting)	1	\$3.70
Parker 801-6-BLK-RL (3/8 BLK hose)	2	\$4.38
Hose clamps	4	\$12.32
Parker 3/8 x 1/4 FF-S (Pipe Nipple)	1	\$1.91
Parker MV609-6 (Female valve)	1	\$15.96
Parker 8-10 F5OX-S (Straight)	2	\$7.32
Parker 12-16 F5OX-S (straight)	1	\$9.56
Parker 12-8 TRTX-S (Reducer)	1	\$5.66
Parker 12 BTX-S (Nut)	1	\$2.13
Parker 6 F5OX-S (Straight)	2	\$4.04
Parker 6 C5OX-S (Elbow)	2	\$14.30
<b>Labor Costs</b>		
Machining or gears and parts	8 hours @ \$60/hr	\$480.00
Tig Welding	2 hours @ \$60/hr	\$120.00
	<b>Total:</b>	<b>\$4,991.20</b>

**Table 4: Cost structure**

Overall, the cost of the bicycle is very high. This partly is due to pricing items individually. Take the handlebars for example. When bicycles are made in high production, the price of the handlebars on the bicycle are not necessarily \$85, this is just the aftermarket price. With this said, the price of the bicycle created is going to be much higher than a production cost of the real thing because parts will not have to be purchased in quantities of one. Also, this bike was created with mostly previously used parts. The parts were pulled from previous years bicycles and modified for the application of this year's bicycle, so this price does not reflect the actual amount paid to create this bicycle.

## 9.0 LESSONS LEARNED

This design competition provided many valuable lessons for all who were involved. It provided opportunity to gain knowledge on applications of hydraulic power, to learn lessons on machining and welding, and to think of creative solutions to a presented set of challenges. Most of the team had a basic technical knowledge of how hydraulic systems operated, but this

challenge created an opportunity to gain first hand experience with these systems and their components. From this, it was learned that hydraulic systems can provide a considerable amount of power to a system with minimal input power, if utilized effectively. The group also learned about machining and the process associated with it. Designing can be an easy task, but making the part capable of being manufactured is a different story. Creating detailed drawings are very important to ensure that the machinist knows exactly what the designer desires, the amount of lead time that is associated with machining, and how to implement the final product into a design. Another lesson learned was communication. It is very important to communicate with all parties when ordering parts and following up on machine work when there are deadlines to meet. There were some errors in the team's order and this set the building of the bike back further than anticipated.

This competition forced the design team to take a common system, a chain driven bicycle, and completely reimagine and redesign its transfer of power. The team quickly discovered that this entailed more than just bolting on a few pumps and motors. It meant thinking of creative solutions to modify the frame and relocate other systems on the bicycle, locations that were unconventional. As a group, learning that there were many different ways to accomplish the same task was a very big learning experience. In the end, the Fluid Powered Vehicle Challenge was an opportunity for many valuable lessons to be learned by the team at The University of Akron.

## 10.0 CONCLUSIONS

The goal from the very beginning was to improve upon last year's bike and to return the University of Akron's team to being innovative and competitive. The objectives for the 2017 University of Akron team were to design a bike that is; lightweight, simplistic and easy to use, has a direct drive circuit, minimize friction, and safe to operate. With these objectives in mind, the design process began. Parts arrived and wrenches began to turn. Upon design iterations and thorough testing, the finished product is a competitive hydraulic bicycle. The final product met our expectations and exceeded them in some areas matching our calculations with real testing.

This competition experience and the memories created would not have been possible had it not been for the National Fluid Power Association and the corporate sponsors that have made acquiring parts and producing a quality bicycle possible. The University of Akron team is grateful to have the opportunity to participate in the Fluid Powered Vehicle Challenge. As our team begins travels to Ames Iowa for the final competition, we look forward to meeting the other teams and adding to our list of great experiences with this project.



APPENDIX A (CAD Model Drawings)



Isometric View 1



Right Side View: This view is ideal for the direct drive system of the bicycle. The Eaton 26 series pump can be seen under the center support of the frame, in front of the pedals. The Eaton 26 series motor is mounted on the rear hub. Also easily seen are the front and rear brakes, located on the front fork and the rear frame, under the saddle.



Left Side View: In this view the accumulation cycle can be seen. The motor charging this system is located on the rear wheel, the 4 way valve mounted under the saddle, the bladder accumulator behind the handlebars and the reservoir located under the valve.

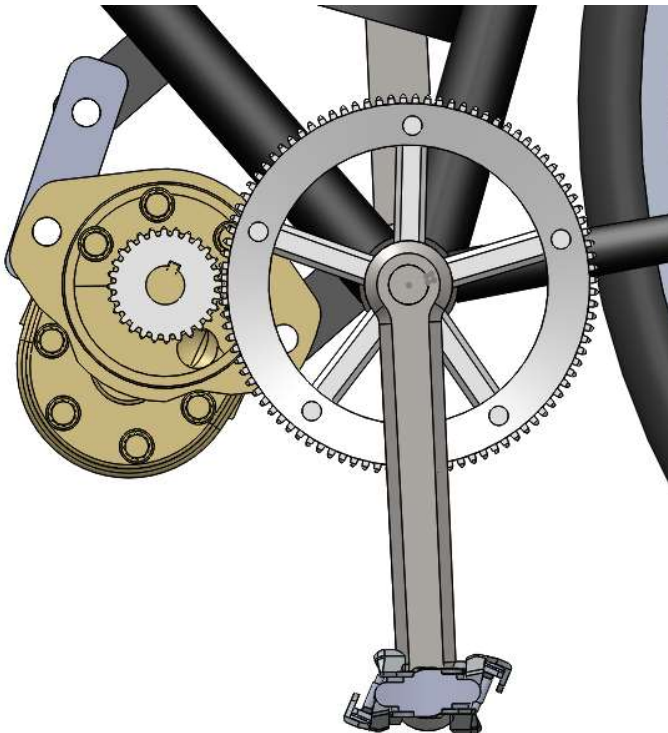

Close Up View 1: This view shows the gearing setup used to turn the Eaton 26 series pump. The crank gear has 96, and the pump gear has 28 teeth.

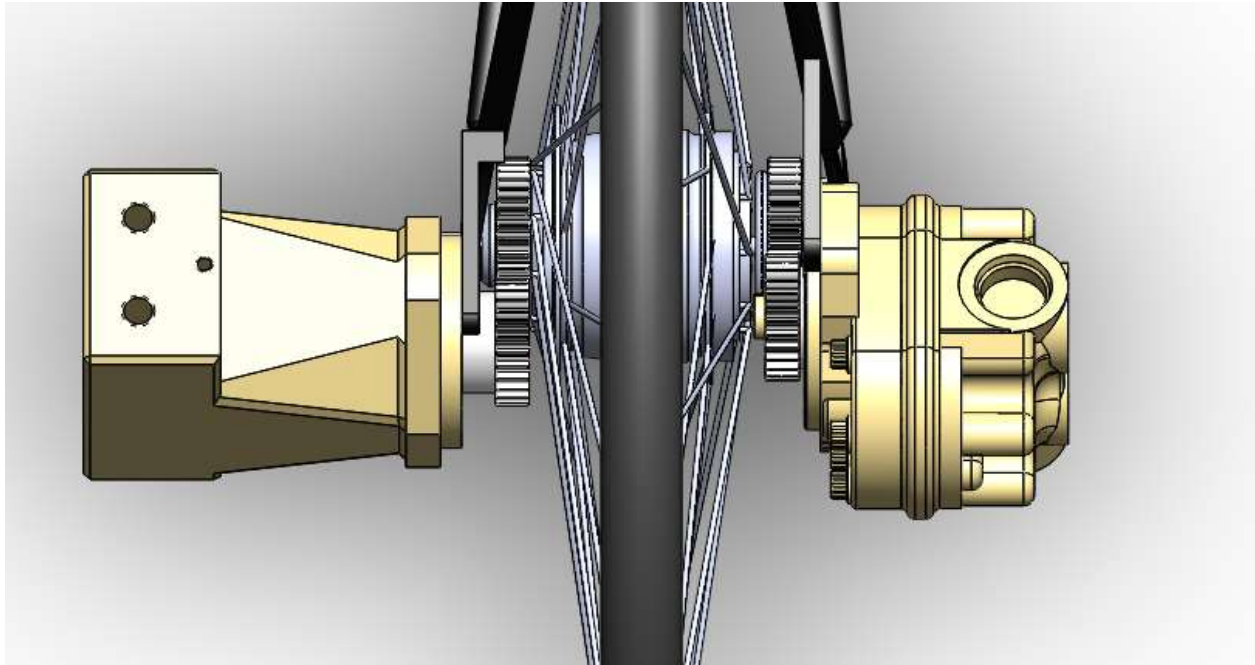

Close Up View 2: This view displays the gearing used on the rear hub and the motors. On the left is the Parker F11 motor used in the accumulation circuit. On the right is the Eaton 26 series motor. This view also shows the custom brackets being used to mount the motors.

## APPENDIX B (Preliminary Calculations)

### Calculations

The preliminary calculation for this project involved calculating the required sizes and capacities of hydraulic pumps and motors. These were done in order to estimate the types and sizes of pumps and motors we would need to power our bicycle. To start out, we estimated several parameters such as the weight of the bike with the rider, the rolling resistance, and the average incline of the road. Those predictions and assumptions are as follows:

- Estimated Gross Weight: 210 lbs
- Rolling Resistance (Concrete): 0.015
- Estimated Incline: 1°
- Wheel Diameter: 26"
- System Pressure: 1000 psi
- Desired Pedal Speed: 60 rpm
- Gear Ratio for Pedal: 5:1
- Motor & Pump Efficiency: 90%

The first step is to determine the required amount of pull for the estimated incline. For a 1.5° incline, the equation is

$$\sin(1^\circ) * 210 \text{ lbs} = \mathbf{3.665 \text{ lbs}}$$

Next, we calculated the required pull to overcome the rolling resistance at the incline:

$$\cos(1^\circ) * 210 \text{ lbs} * 0.015 = \mathbf{3.15 \text{ lbs}}$$

The total pull required is simply these two pulls added together. The pull required for uphill is 3.665 lbs + 3.15 lbs = **6.815 lbs**. The pull required for downhill is 3.15 lbs - 3.665 lbs = **-0.515 lbs**.

This means that on concrete, the our bicycle will roll down by itself on a 1° incline.

Next, we needed to calculate the torque required for the hydraulic motor. The torque required is given by the following equation:

$$\tau = \text{wheel radius} * \text{total pull} = 13" * 6.815 \text{ lbs} = \mathbf{88.59 \text{ lb in}}$$

Then, using the calculated torque, we could find the required CIR (cubic inches per revolution) for our motor.

$$\tau = \frac{CIR * PSI}{2\pi} \rightarrow CIR = \frac{88.59 \text{ lbs in} * 2\pi}{1000} = \mathbf{0.557 \text{ CIR}}$$

From our estimated efficiency of 90%, our adjusted value for CIR is **0.618 CIR**. Then we converted CIR into cubic centimeters per revolution. That value is equal to **10.135 cc/rev**.

To calculate the needed RPM, GPM (Gallons Per Minute), and horsepower required, we used the following equations:

$$RPM = \frac{336 * MPH}{\text{wheel dia}} = \frac{336 * 15 \text{ mph}}{26"} = \mathbf{193.86 \text{ rpm}}$$

$$GPM = \frac{CIR * RPM}{231} = \frac{0.618 \text{ CIR} * 193.86 \text{ rpm}}{231} = \mathbf{0.519 \text{ GPM}}$$

→90% Efficiency: **0.577 GPM**

$$HP = \frac{GPM * PSI}{1714} = \frac{0.577 * 1000}{1714} = \mathbf{0.336 \text{ HP}}$$

Finally, once we had our requirements for the motor, we could then size the pump. We calculated the CIR required by using the calculated gallons per minute value. Those steps are outlined below.

$$GPM = \frac{CIR * RPM}{231}, \text{ where } RPM = \text{geared RPM}$$

$$\text{Rearranging, } CIR = \frac{0.618 * 231}{325} = \mathbf{0.41 \text{ CIR}}$$

Taking into account the efficiency, the new CIR value is  $0.41/0.90 = \mathbf{0.51 \text{ CIR}}$ . Converting into cubic centimeters per revolution, we obtain the value of **8.29 cc/rev**.

### APPENDIX C (Engineering Drawings)

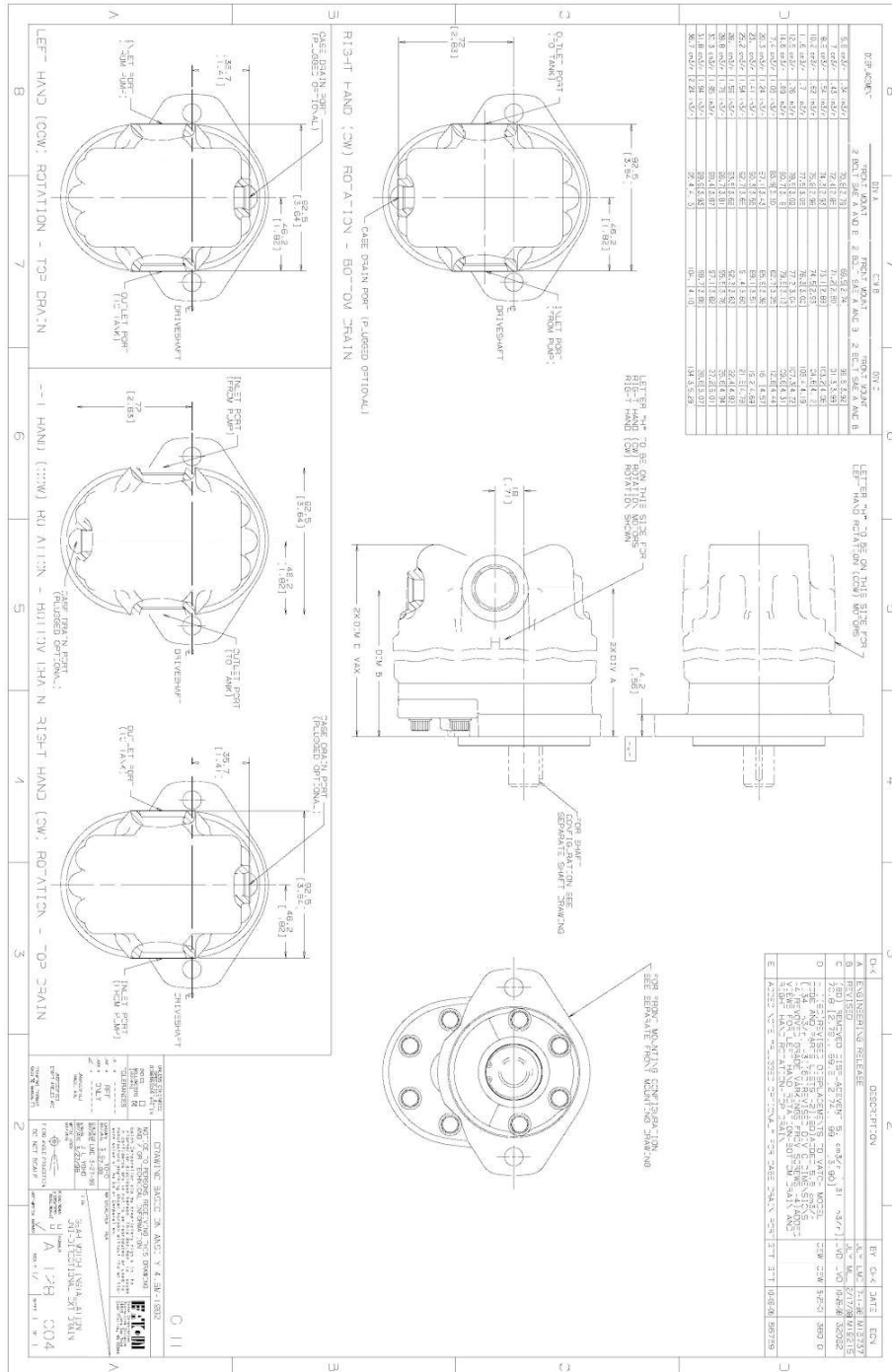

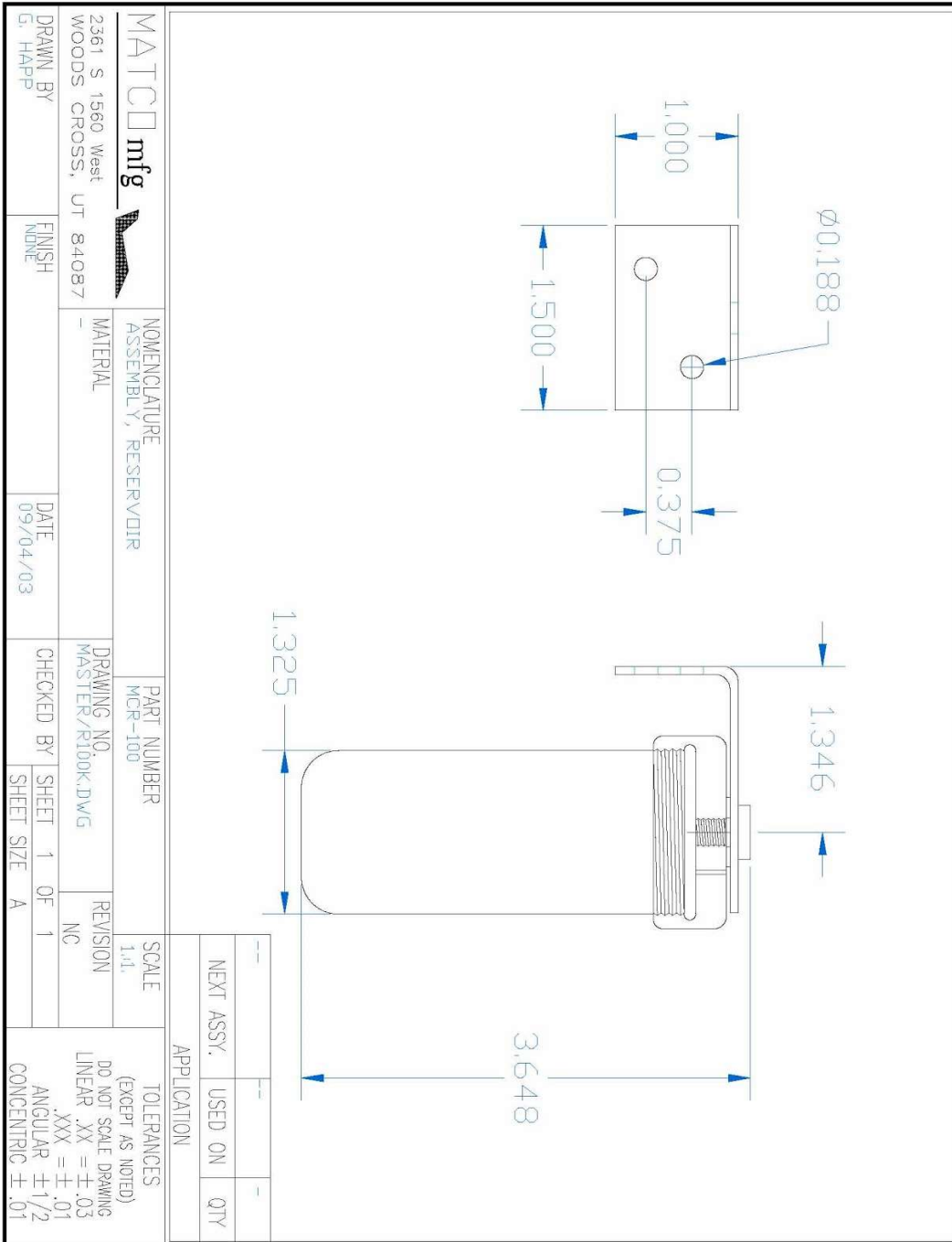



Catalogue HY17-8249/US  
**Installation dimensions**

Hydraulic motor/pump  
**Series F11/F12**

**F11-5**  
 (CETOP versions)

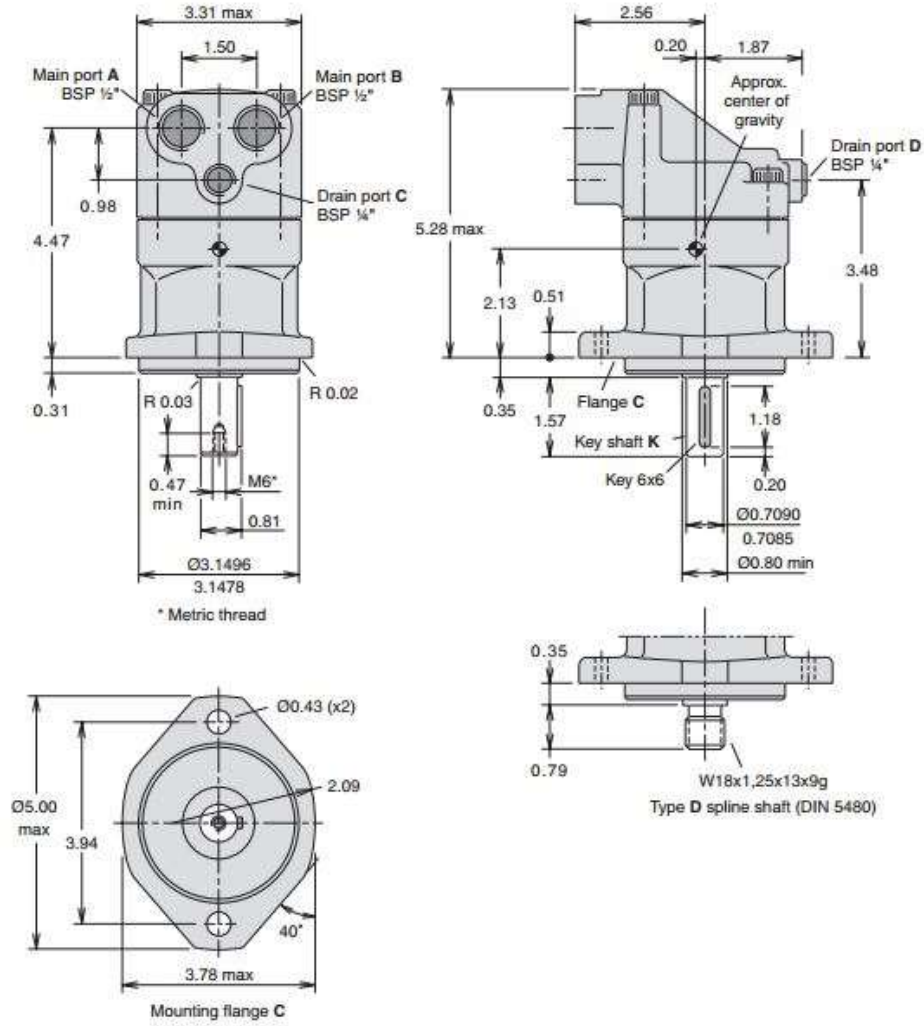

**MRV4-10 (V)-\*\*-\*\*-00**

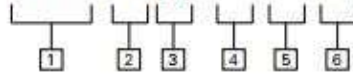

**1 Function**

**MRV4** - Manual rotary valve  
 4 way

**2 Size**

**10** - 10 Size

**3 Seals**

**Blank** - Buna-N  
**V** - Viton®

**4 Manual operators**

- O** - No operator
- D** - Lever (3-position detent)\*
- D2** - Lever (2-position detent)\*
- E** - Ball (3-position detent)\*
- E2** - Ball (2-position detent)\*
- K** - Knob (2-position, no detent)

\*Light duty housing only.

**5 Port size**

**O** - Cartridge only

CODE	PORT SIZE	HOUSING NUMBER	
		Aluminum Light duty	Aluminum Fatigue rated
<b>3B</b>	3/8" BSPP	02-179705	-
<b>6T</b>	SAE 6	566161	-
<b>2G</b>	1/4" BSPP	-	876709
<b>3G</b>	3/8" BSPP	-	876715
<b>6H</b>	SAE 6	-	876708
<b>8H</b>	SAE 8	-	876713

See section J for housing details.

**Dimensions**

mm (inch)

Torque cartridge in aluminum housing  
 47-54 Nm (35-40 ft. lbs)

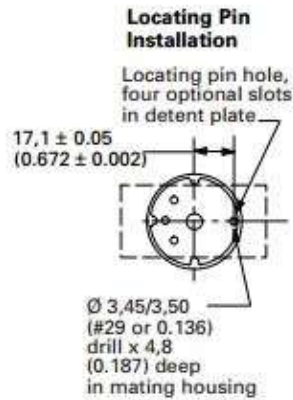

**MRV4-\*\*(V)-D(2)**

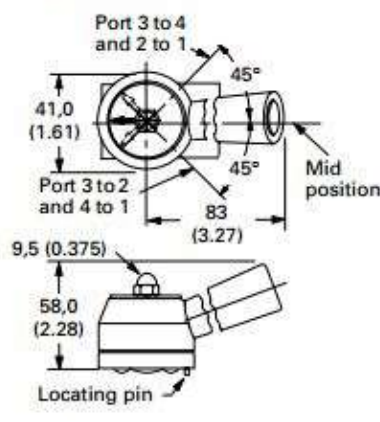

**MRV4-\*\*(V)-E(2)**

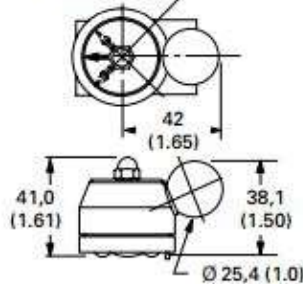

**6 Special features**

**00** - None  
 (Only required if valve has special features, omitted if "00")

**MRV4-\*\*(V)-K**

Arrow can be relocated by slackening the domed nut and turning the plate. Re-tighten nut.

