

# HINTS FOR DEVICE DESIGN AND CONSTRUCTION

WOODEN BASE WITH  $\frac{7}{8}$ " HOLE:

Can be placed in several positions:

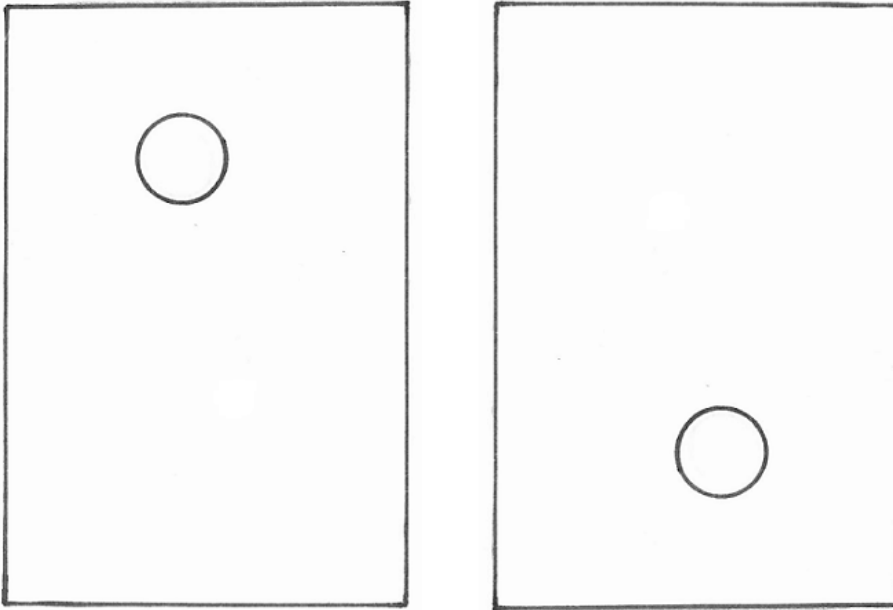

$\frac{7}{8}$ " DOWEL TO FIT HOLE IN BASE – APPROX  $3\frac{7}{8}$ "

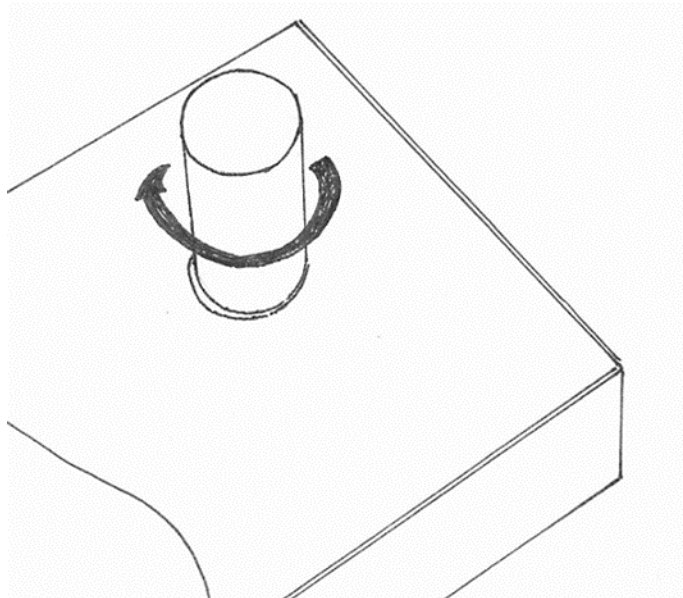

Ensure the dowel rotates in the hole. This may require cleaning the hole and sanding the dowel.

THE DOWEL ALSO FITS THE 4" SQUARE PLATFORM:

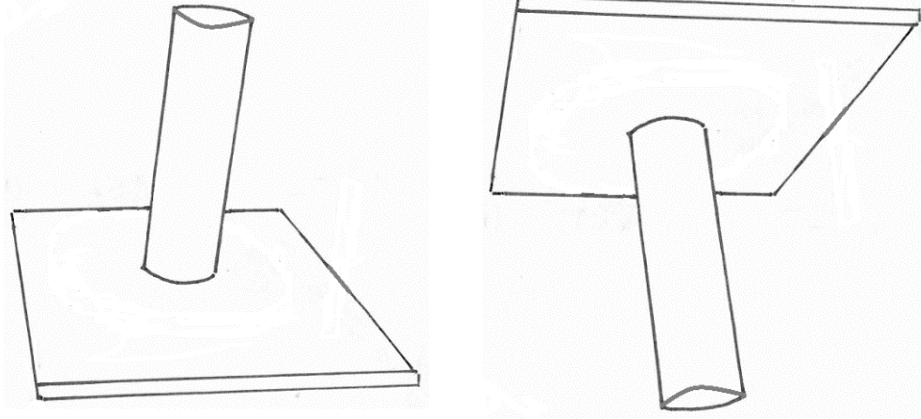

BOTH PLATFORMS CAN BE ATTACHED TO THE DOWEL AND BLOCK:

(Question is: How will the two platforms be supported if a large mass is fixed to the top platform?)

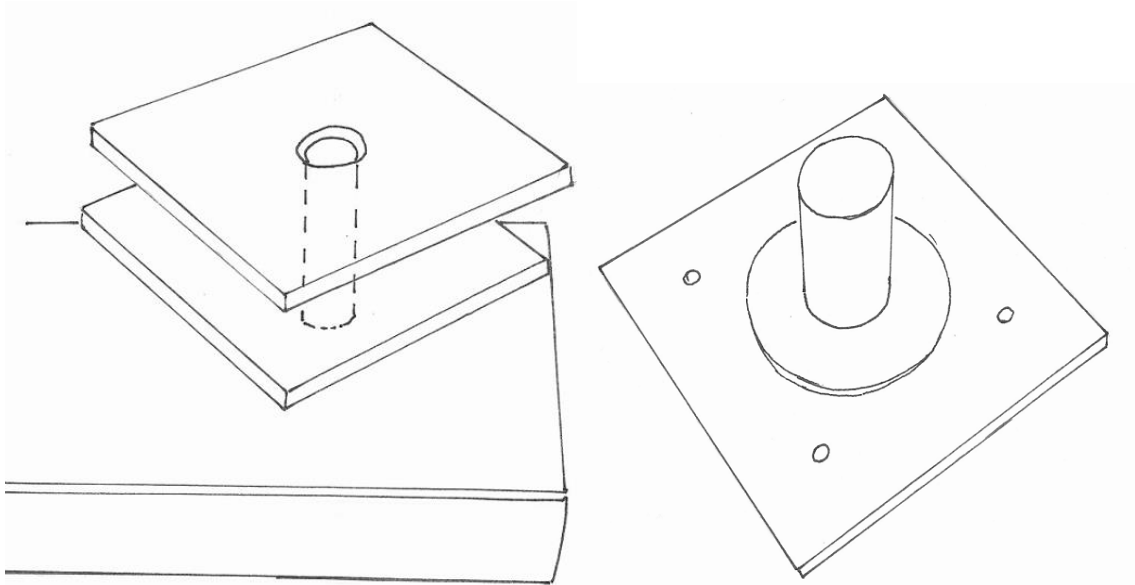

LARGE WHEEL WITH  $\frac{7}{8}$ " HOLE ALSO FITS THE  $\frac{7}{8}$ " DIAMETER DOWEL

In the diagram above the wheel glued to the underside of the platform is used to provide additional strength. The holes are for smaller dowels to fit through

WOODEN PIECES (2 FT., 3/8" CROSS-SECTION):

The wooden pieces are used for the frame structure of the device, joined together using the green card corners and a small amount of wood glue. The wood glue can also join pieces of wood together.

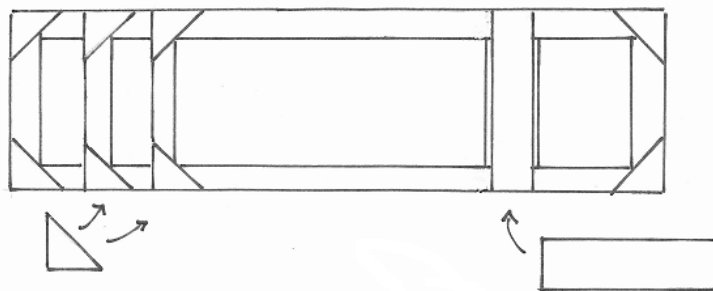
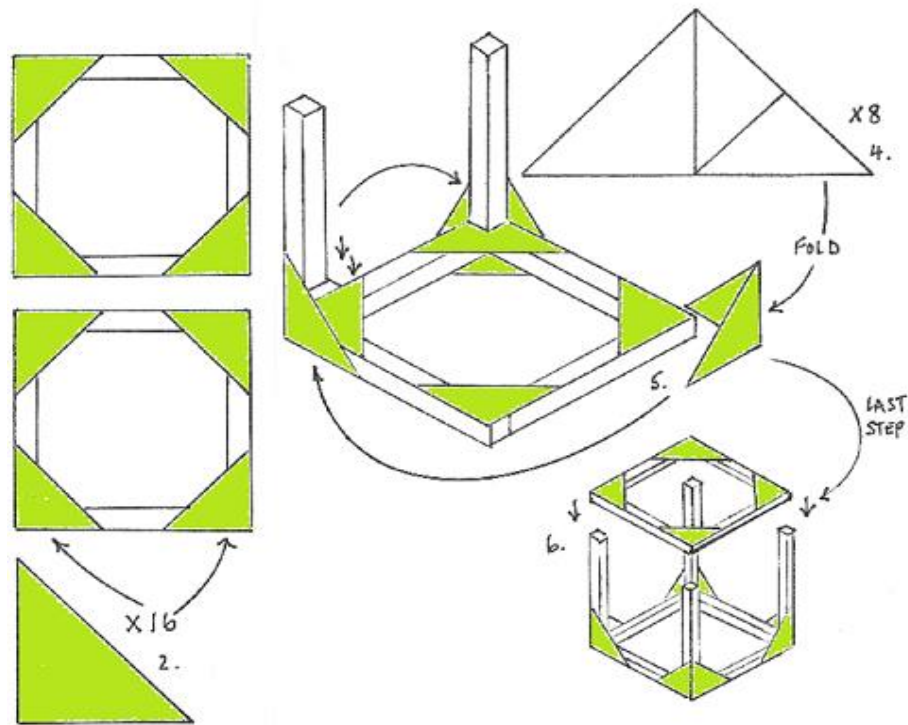
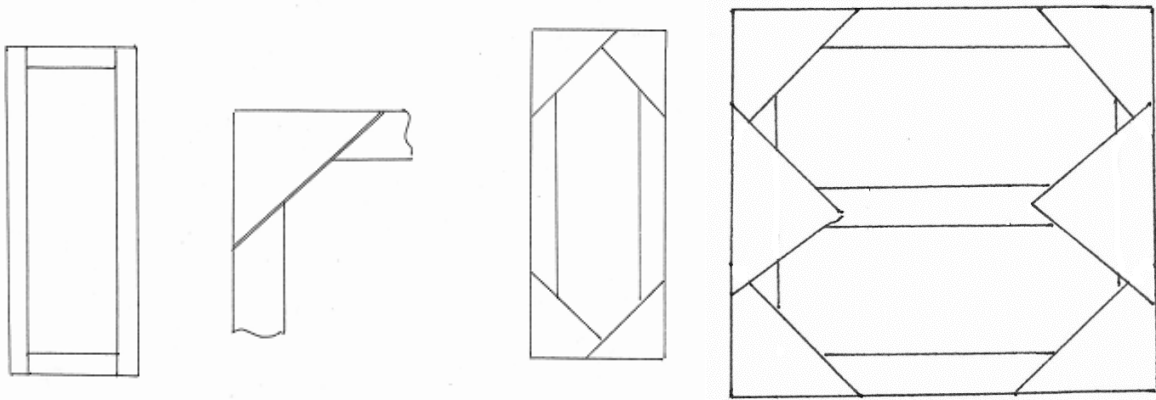

Wooden pieces used to support wooden uprights on the block:

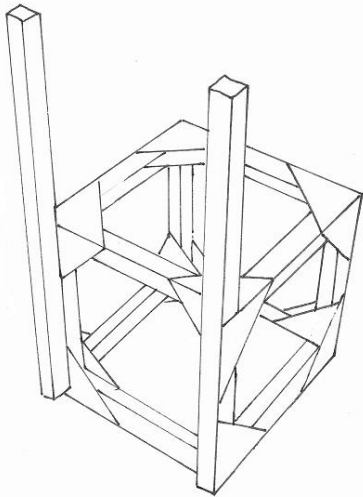
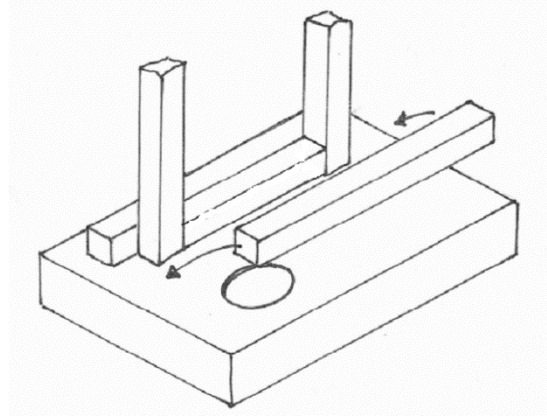

A part of the frame for the lifter. The longer pieces are glued to a cube using the green cardboard corners or gussets. It is not necessary to put glue between the pieces of wood when joining them. It is enough to put a small amount of glue onto the cardboard triangle.

It must dry properly to hold the wood firmly in place.

SPECIAL WOODEN PIECES:  $19\frac{3}{4}'' \times \frac{3}{8}''$  CROSS-SECTION, with 3 holes:

Each piece has 3 pre-drilled holes that the smaller dowel will rotate through. It is important to line the holes up correctly. A piece of dowel is used in the diagram below to keep the pieces square:

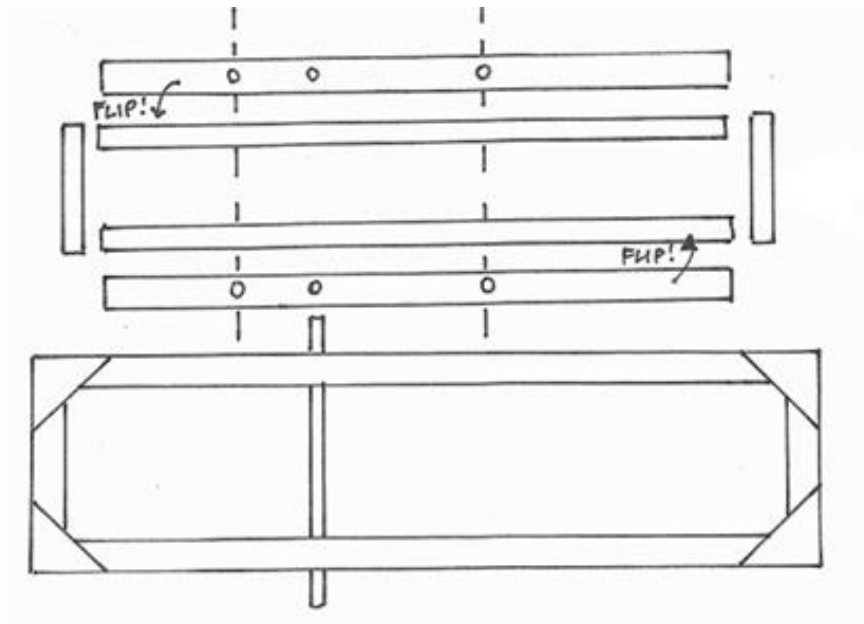

In the diagram below three small pieces with holes drilled in the middle are joined together to make a small platform that will rotate on a dowel. A hole made using a  $7/32$ " drill bit creates a hole for the dowel rotate freely, a  $13/64$ " drill bit creates a hole that is a tight fit for the dowel.

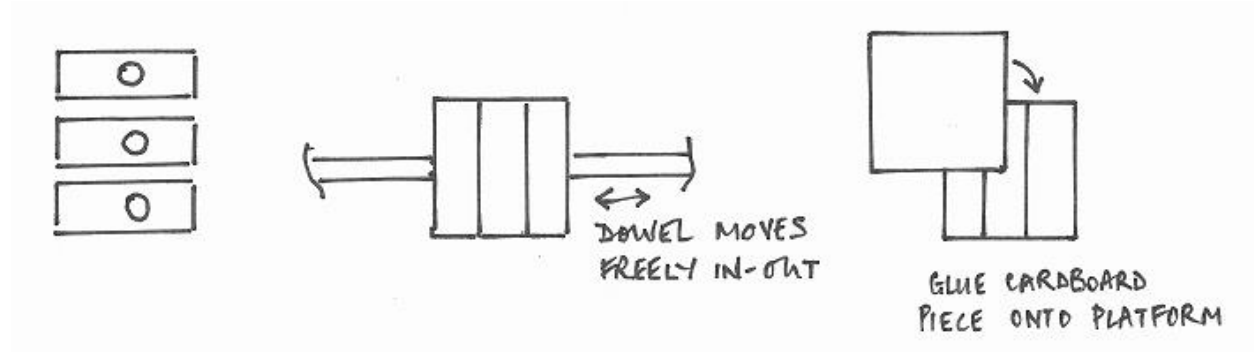

In this section of the model the small platform will support a holder for the piston-syringes:

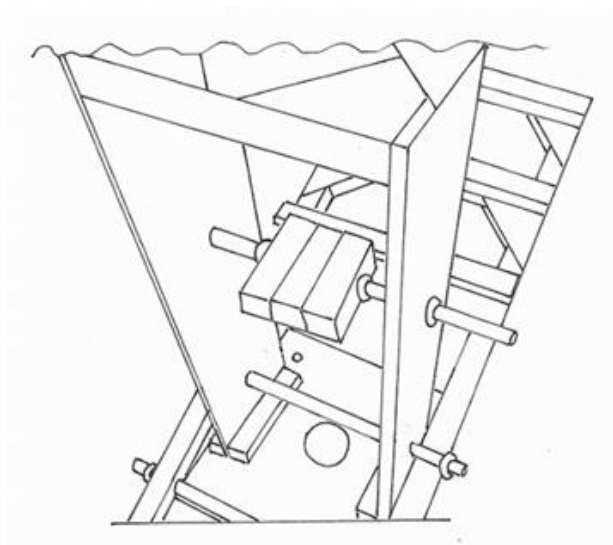

WHITE AXLE HOLDERS:

The thicker white axle holders are glued to the frame to support dowel:

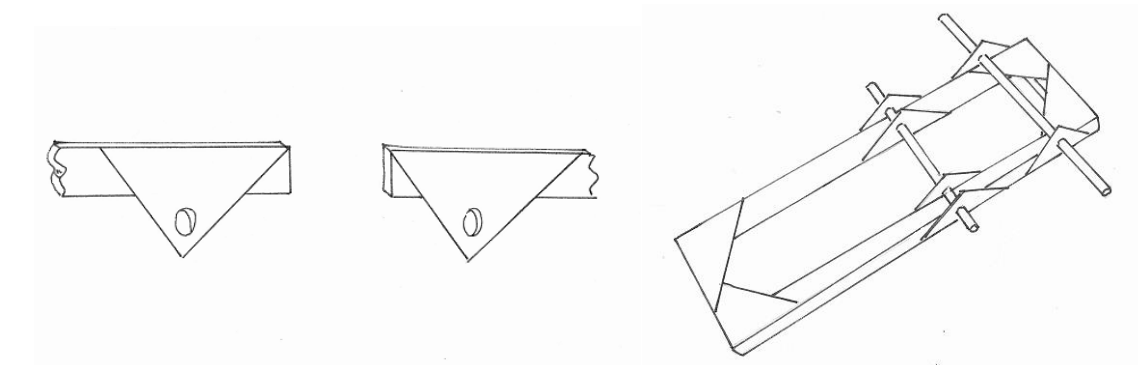

Use the dowel axes to make sure that the axle holders are square:

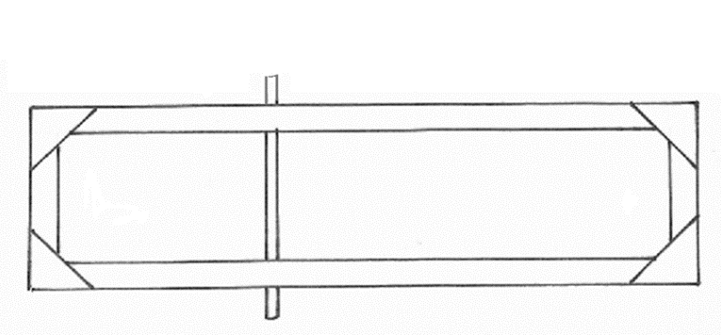
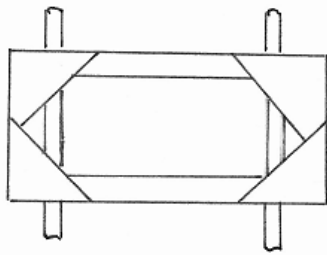

Use the small black O-Rings to hold the pistons and axles in place

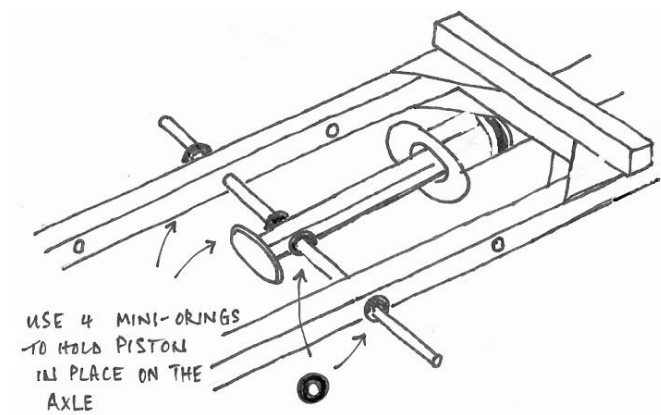
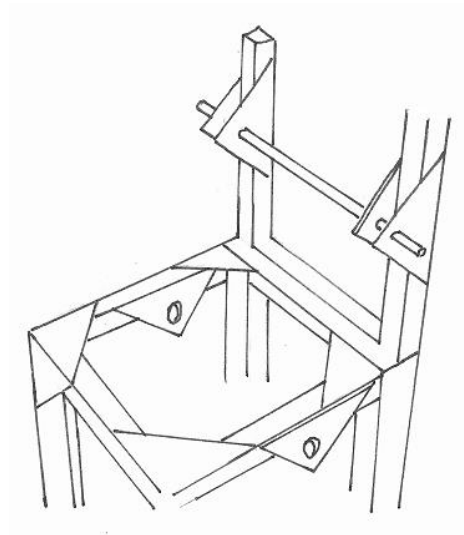

The dowel axes are used with the white axle holders or through the holes drilled in the wood. They will support the small platforms for mounting the piston syringe holders

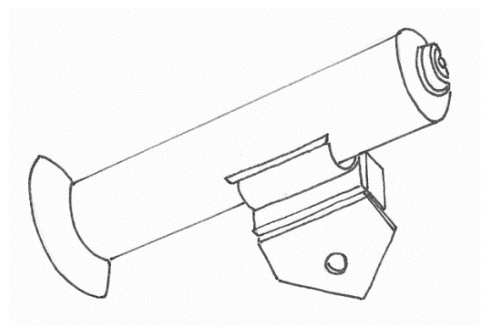
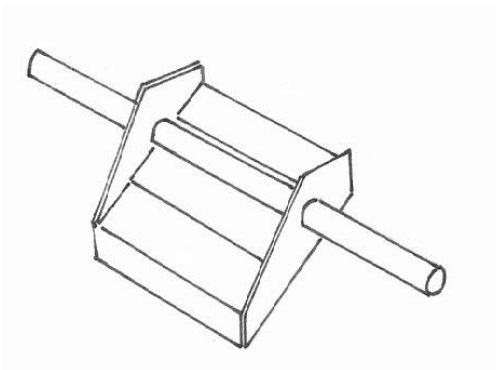

PISTON-SYRINGE HOLDERS:

Gray holders: - larger sticky pad, use to hold 20cc syringes exerting most force

White holders: - smaller sticky pad, use with a piece of double-sided tape to hold 10cc syringe in place.

White holders also tightly fit 20cc syringes

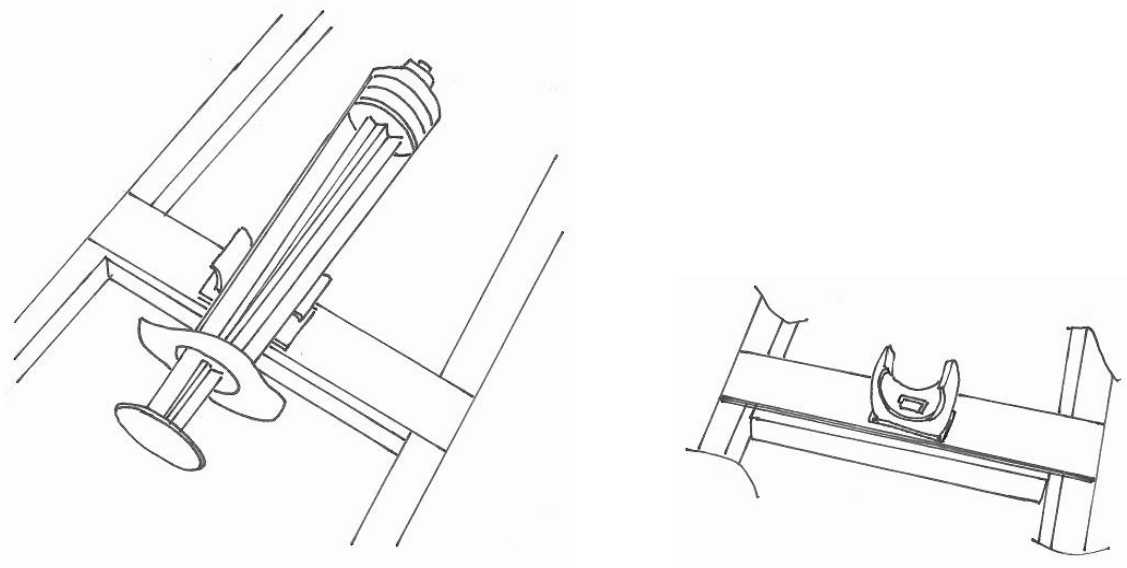

Use a gray holder for the platform, made from the smaller wheels, that will turn the device and the platform that will hold the piston syringes whose plungers attach to axles for lifting:

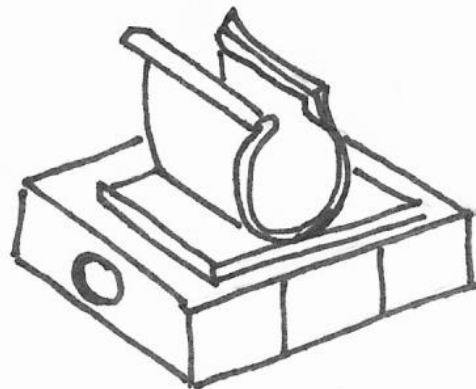
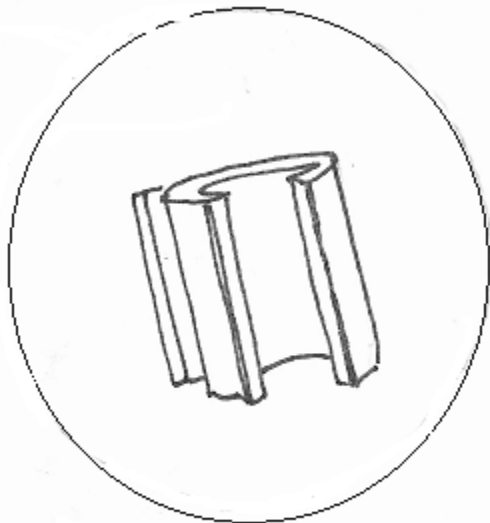

SYRINGES:

6 X 20cc (3 with hole drilled in plunger); 2 X 10cc (1 drilled) (Workshop and Selected Team kits)

8 X 20cc (4 with hole drilled in plunger); 2 X 10cc (1 drilled) (Challenge kit)

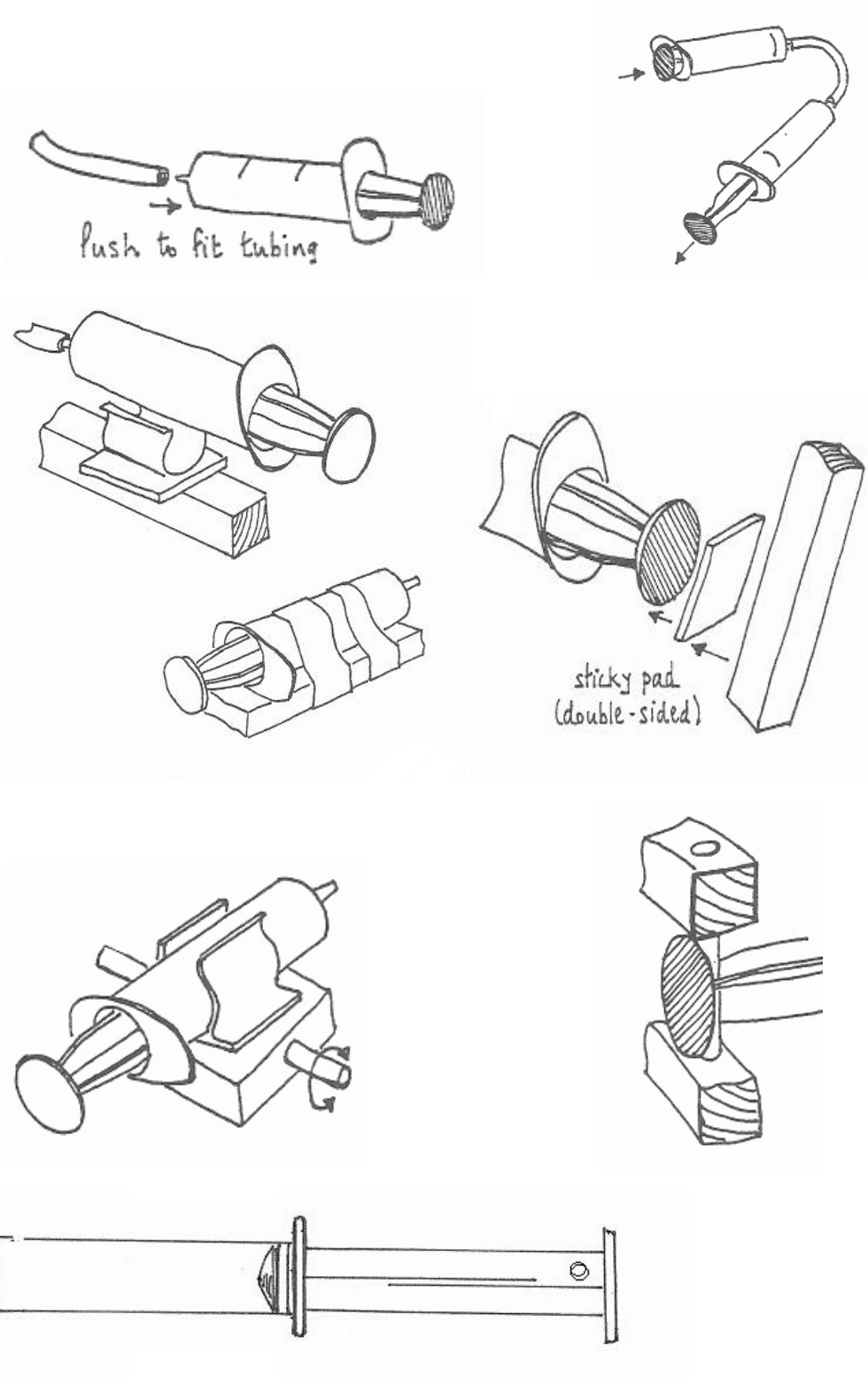



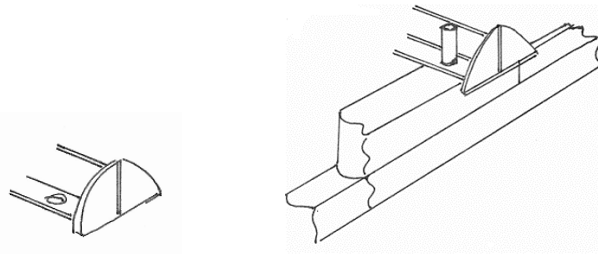

**CREATING A STABLE BASE:**

1. Check out the layout for the Challenge.

This year’s Challenge uses a small footprint. The block can be placed in the footprint in different ways so that the position of the hole changes. Your team may choose not to use the block – in this case your structure must fit inside the walls of the footprint.

2. Read the Challenge to get an idea of what must happen, why there are different zones and how far the arm that picks up the object must move up, rotate and, if your team chooses, extend.

3. However your team decides to meet the Challenge your device will have to have a stable base that supports a frame structure. This structure will hold the syringe-pistons in place and those pistons will power mechanisms that grab, lift and move the object according to what zone your team decides to go for. You may choose to design your own base structure or use the wooden block in the kit

4. How can the block be used to support a frame?

The frame could be built directly onto the block:

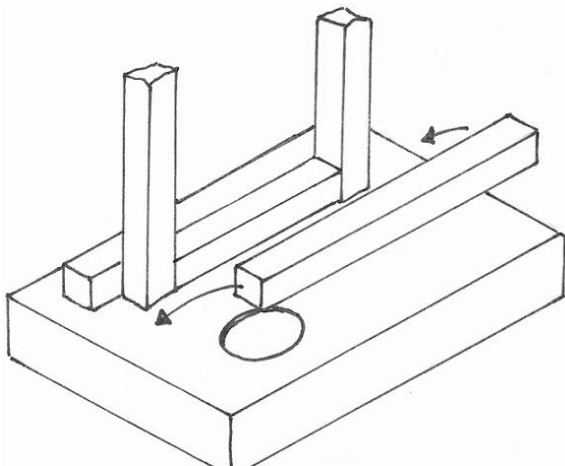

In this case the vertical uprights will need to be firmly fixed to the block and supported by a foundation “wall”. The frame will need a section that rotates somewhere above.

Alternatively, the large dowel and the 4” platforms can be used. This introduces rotation immediately.

The rotating frame could also be mounted on the 4” platforms and extend over its sides according to your team’s design.

It is very important that the base and the frame, however designed, are strong and stable. It is therefore wise to allow the wood glue to dry – and use a small amount of glue to speed up the process.

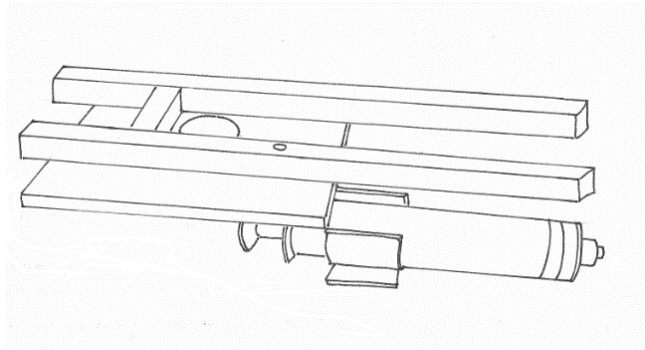
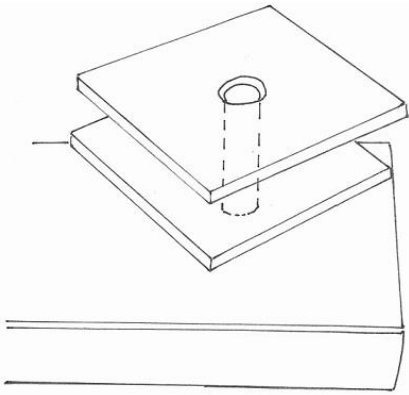

In the diagram below the 4" platform and the vertical wooden pieces has been drilled with holes to give additional support by inserting dowel rods:

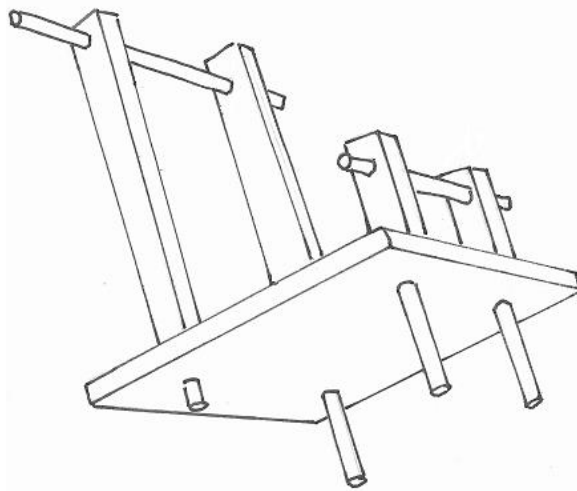

Here's a set-up for a rotating tower mounted on platforms connected to a small wheel platform that has the piston syringe that will causes rotation. The tower has addition beams to support a piston syringe that will raise the arm

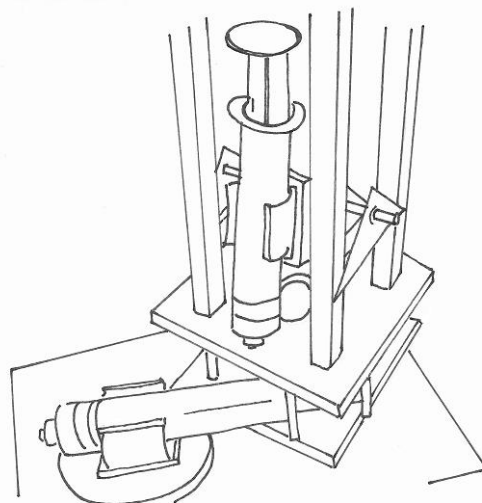

## RAISING THE ARM:

As in the Lifter:

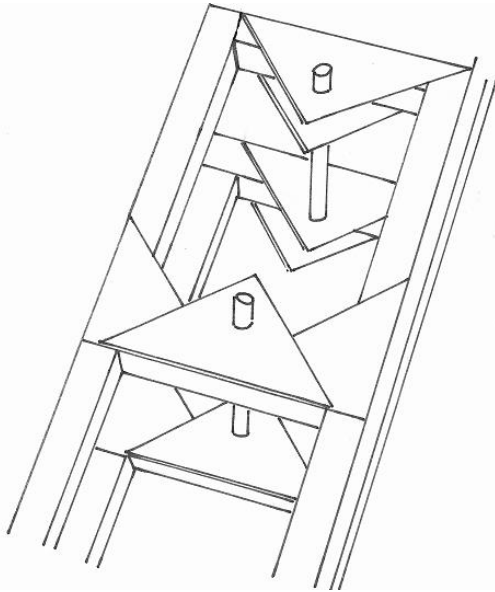

Above: supports for piston platforms

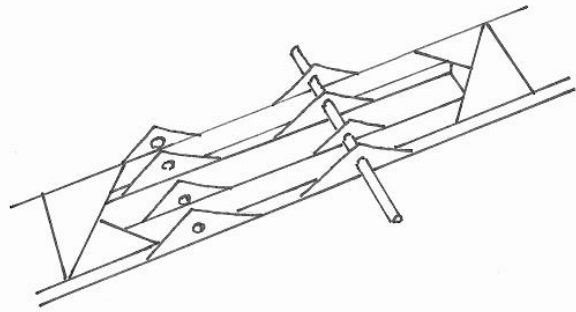

Plungers of pistons connect to dowels on the arm

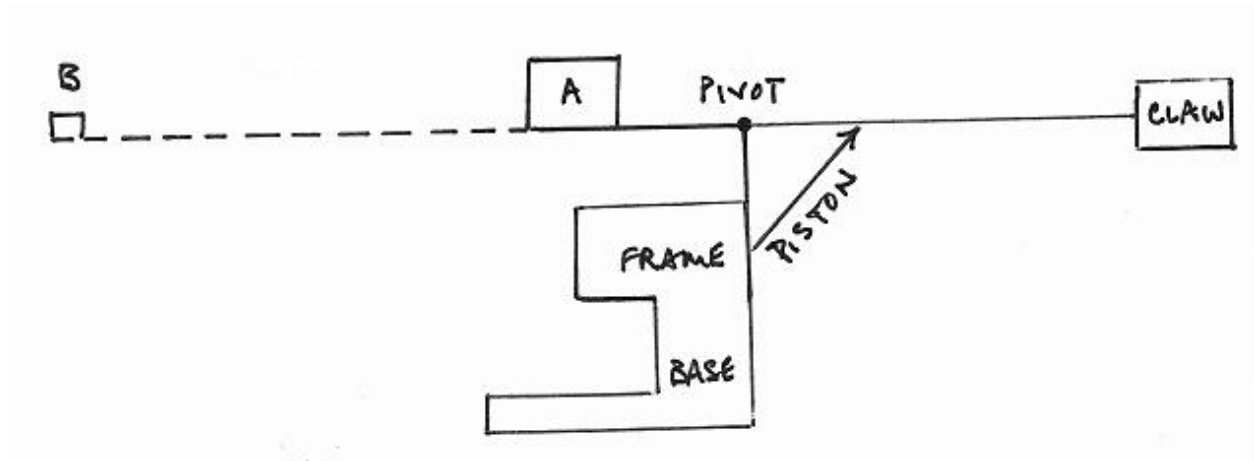

Counterbalance:

In the diagram above the body of the device fits into the area named "Frame / Base ". A piston is attached to the arm and claw mechanism. A larger counterbalance is required at "A" compared to "B".

If the connection of the piston and arm were closer to the claw less effort is required to raise it.

Figuring out where to place the pistons and counterbalance is an important part of building a successful device.

IDEAS FOR EXTENDING THE ARM:

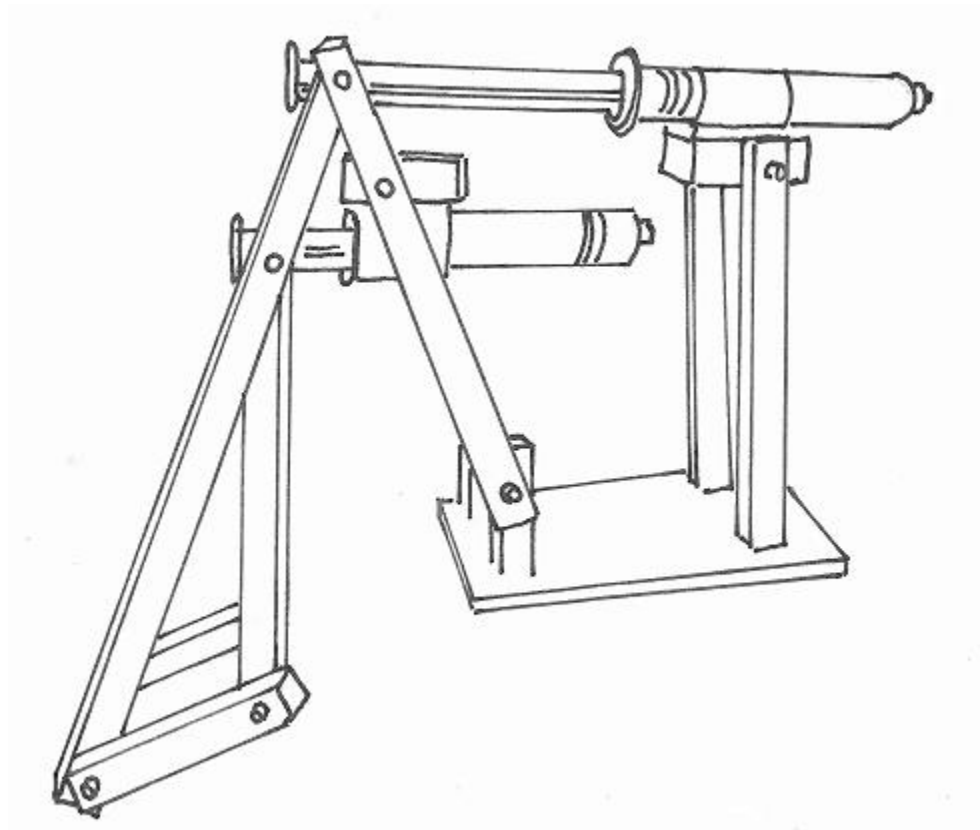
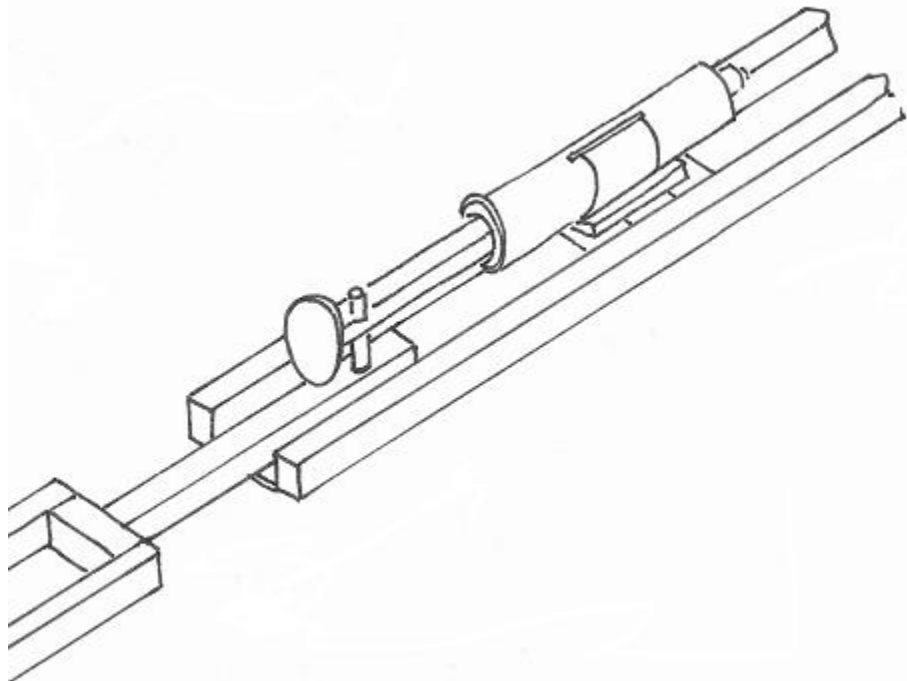

IDEAS FOR GRABBING MECHANISMS:

