

**Development of Fluid-Power Based Modules for Fluid Mechanics and
Thermodynamics Courses Utilizing Problem-Based Learning and
Entrepreneurially-Minded Learning**

NFPA Curriculum Development Grant Supplemental Materials

Submitted by:

Liping Liu, Ph.D.
James Mynderse, Ph.D.
Robert Fletcher, Ph.D.
Andrew Gerhart, Ph.D.

**A. Leon Linton Department of Mechanical Engineering
Lawrence Technological University**

Appendix A-1: Assignment A in Thermodynamics

EGE3003 Fall 2017

HW "A" on Pneumatics Engineering – 30 points

Issued: September 11, 2017

Due: September 18, 2017

Introduction: The area of Pneumatics Engineering is an important one for many industries involved in manufacturing, production, or material conveyance. It falls under the larger classification of "Fluid Power". In this assignment you will begin to learn about the area of Pneumatics Engineering and how it relates to our EGE 3003 Thermodynamics course.

1) Watch the following three videos. Then answer the questions after each.

<https://www.youtube.com/watch?v=fM11hGJnqtQ> (Youtube video titled "Introduction to pneumatics")

- Describe in some detail the basic operations you see in this video that are powered by pneumatic systems, or compressed air. (2 points)
- List and discuss the advantages to pneumatic systems given in this video. (2 points)

<https://www.youtube.com/watch?v=0zIINr3Vqj4> (Youtube video titled "Pneumatic Desktop capping machine with printing function for semi-auto shampoo production line")

- You may need to watch this video a few times to see what is happening. Describe in detail what is taking place. Why is this operation beneficial? Would this be better done by manual labor? Why, or why not? (2 points)

<https://www.youtube.com/watch?v=uRpxhIX4Ga0> (Youtube video titled "A car that runs on air")

- The AirPod car is a vehicle powered by pneumatics (compressed air). Describe the history of using compressed air to provide power to move a vehicle. (2 points)
- What are the advantages to using a compressed air vehicle? Do you think it is practical? Why or why not? (2 points)

2) Describe the basic components that would be needed in producing, storing and delivering enough high-pressure air to power machines, production lines, or even vehicles. Go online to find references that can supplement and justify your answers. List and describe these references. (5 points)

3) In chapter 3 of our Thermodynamics textbook we are learning about the nature of gases and the issues they face when compressed to high pressures. Review all of sections 3.11 and 3.12.

- Describe the issues that are presented in these sections relating to compressed gases. (2 points)
- How would a thorough understanding of these topics be beneficial in pneumatics engineering applications and systems? Why? Elaborate upon your answer in detail. (2 points)

4) The area of pneumatics engineering falls under the larger umbrella of Fluid Power. This area is so important in industry that there is a professional organization devoted to assisting and supporting engineers and manufacturing system designers in using fluid power. This organization is the National Fluid Power Association (NFPA). Their website is located at:

<http://www.nfpa.com/>

- Go to their website and review the various sections of their website. Describe what the NFPA sees as their mission. (2 points)
- Under the "What is Fluid Power?", they discuss several topics. Briefly describe these various topics. (2 points)
- How they define pneumatics? (2 points)
- They also give an example of how "a fluid pressure of 1,000 psi can push with 3140 lbs. of force. A pneumatic cylinder using 100 psi air would need a bore (diameter) of approximately 6½ in. to develop the same force." Quantitatively (by calculations) show how this is so. (2 points)
- Go to the "Workforce" section on the upper heading of website. Under the "Fluid Power Careers", then "Job Information" section review, list and describe in five or six sentences each three different types of job positions and the associated responsibilities. In addition pick three companies and describe how they may use pneumatics. (3 points)

Appendix A-2: Student Work Sample

EGE3003 Fall 2017

HW "A" on Pneumatics Engineering – 30 points

Issued: September 26, 2017

Due: October 3, 2017

430
30

Introduction: The area of Pneumatics Engineering is an important one for many industries involved in manufacturing, production, or material conveyance. It falls under the larger classification of "Fluid Power". In this assignment you will begin to learn about the area of Pneumatics Engineering and how it relates to our EGE 3003 Thermodynamics course.

1) Watch the following three videos. Then answer the questions after each.

- a) Describe in some detail the basic operations you see in this video that are powered by pneumatic systems, or compressed air. (2 points)

For this question, I felt it could be best organized in bullet-point form. Below are descriptions of the pneumatic processes that I spotted in the video in this format, in order of appearance.

- Move a plastic cylinder back and forth. There was no other purpose for this other than showing pneumatics in action.
- Turn an unknown component about 90 degrees, then move the entire assembly (that includes the aforementioned component) horizontally several inches.
- Flip a drill from a vertical orientation to a horizontal. Pneumatics was then used to push the drill forward about 6 inches and drill into a product on a moving assembly line wheel.
- Grab rows of milk jugs off of a conveyor belt and place them in a grid-like orientation in boxes.
- Nudge glass jars into the spaces on a slotted assembly line wheel.
- Inflate an ordinary balloon using a 50 lb air cylinder.
- Perform an unknown action to chocolate bars. The chocolate bars are on a moving assembly line and pneumatics are used to systematically and periodically push a bar lengthwise down onto them. The purpose of this function or what, exactly, this function is doing to the chocolate bars is unclear due to camera orientation.
- Perform an unknown function inside of a variable temperature environment. A complex pneumatic 'hub,' with many tubes and components is shown in the video, but there is no indication of its purpose.
- Grab and move components off of a moving assembly line wheel and drop them into metal chutes for collection.

b) List and discuss the advantages to pneumatic systems given in this video. (2 points)

1. Pneumatics systems are fast and assembly of components has short cycle times, so assembly lines can be much quicker and more parts produced.
2. Pneumatic systems are clean for the environment and for workers, as the compressed air that they use cannot contaminate anything and can simply be put back into the atmosphere.
3. Pneumatic systems are unaffected by changes in temperature, so they can be used in assembly processes involving variable temperatures.
4. Pneumatic systems are reliable and break down less often, so the less time spent fixing it is more time making parts.
5. The air in pneumatic systems can be stored for long periods of time, making them even more versatile.
6. Pneumatic systems are relatively inexpensive.

c) You may need to watch this video a few times to see what is happening. Describe in detail what is taking place. Why is this operation beneficial? Would this be better done by manual labor? Why, or why not? (2 points)

It appears that the machine's purpose is to screw the caps of shampoo bottles onto the bottles, themselves. It also prints the date of manufacture on the bottles. This operation is necessary in order to close the shampoo containers for shipping and sale, so that the shampoo is not spilled. In addition, dating the bottles is done in order to alert someone that a bottle is too old. This entire operation would not be better

done by manual labor, as a person would not be able to do these two steps in a way that is efficient enough to allow for fast assembly. In conjunction with this, the pneumatic device in the video can perform this operation on several dozen more bottles per minute than a human could.

d) The AirPod car is a vehicle powered by pneumatics (compressed air). Describe the history of using compressed air to provide power to move a vehicle. (2 points)

+2 *It took approximately 14 years for R&D of the AirPod since prior to the year 2000. This vehicle is by no means the first vehicle powered by compressed air, as the first engine powered by compressed air was made in 1820. However, many automotive engineers have found compressed air difficult to work with, and limited efforts have gone into exploring the feasibility of compressed air by major automakers. The AirPod is the first compressed air vehicle that is truly environmentally friendly and, more importantly, economically viable. One of the world's largest automakers, Tata Motors, developed a relationship in 2009 with MDI in order to launch an engine powered by compressed air in 2011. Another automaker, Peugeot (a sister company of Citroen) is planning to investigate the creation of a hybrid setup.*

e) What are the advantages to using a compressed air vehicle? Do you think it is practical? Why or why not? (2 points)

+2 *The advantages to using a compressed air vehicle are mainly environmental. The AirPod's motor does not give off the harmful pollutants that gas engines do. You can also 'refuel' it at home, given you have the proper setup. As far as practicality goes, the Air Pod is perfect for places like India with a great deal of pollution and urban driving, but I cannot see the vehicle catching on here in the US.*

2) Describe the basic components that would be needed in producing, storing and delivering enough high-pressure air to power machines, production lines, or even vehicles. Go online to find references that can supplement and justify your answers. List and describe these references. (5 points)

+5 *For this answer, I felt it would be better for organization for the answer to be laid out in a list or bullet point format. So, below are some of the basic components needed in producing, storing, and delivering high pressure air:*

1. *A high pressure tank to hold pressurized air. This can vary in size, according to the manufacturer's needs.*
2. *A filter to filter particulates out from the air, so that the machinery does not get damaged from dust and dirt.*
3. *High pressure hoses, fittings, and lines to move air from one component to another. These should be particularly sturdy and reliable, as hosing is where many pneumatic systems fail.*
4. *A compressor, to compress air to the pressures required for storage and power delivery. Several of these can be paired together in order to improve the pressure that the air can be compressed to.*
5. *An air dryer or separator, in order to remove moisture from the air and greatly improve its compressibility.*
6. *A flow controller that fine-tunes the amount of airflow into any one component of the system.*
7. *A user-interface that allows people to control the functions of the system of components mentioned.*
8. *A well-designed ventilation system.*
9. *Variable speed drive for the compressor, depending on the type. This device allows the compressor to spin at a variable rate of speed, depending on user input.*
10. *Condensate management devices and drains. These are to control the water that is a by-product of high pressure air production.*

Sources:

- *Kaeser Compressors: http://www.kaeser.ca/Images/USGUIDE3_DesigningYourCompAirSys-tcm67-12601.pdf. Kaeser is a major manufacturer of air compressors, including ones for industrial use.*
- *Compressed Air and Gas Institute: <http://www.cagi.org/pdfs/cagi-air-compressorhp.pdf>. CAGI is a professional organization that promotes and educates about the use of compressed air and gas.*
- *Popular Mechanics: <http://www.popularmechanics.com/home/how-to/a151/how-air-compressors-work/>. Popular Mechanics is a well-respected technology-oriented magazine publication.*

3) In chapter 3 of our Thermodynamics textbook we are learning about the nature of gases and the issues they face when compressed to high pressures. Review all of sections 3.11 and 3.12.

a) Describe the issues that are presented in these sections relating to compressed gases. (2 points)

Some of the issues relating to compressed air presented in these sections include those relating to the compressibility factor and the ideal gas law. The ideal gas law dictates that when you keep volume constant and increase the pressure, the temperature increases. This must be accounted for in high-pressure applications. In addition, the compressibility factor is a scalar quantity describing how well a gas compresses. If the compressibility factor is too high, any gas will not be able to have a sufficient high pressure.

- b) How would a thorough understanding of these topics be beneficial in pneumatics engineering applications and systems? Why? Elaborate upon your answer in detail. (2 points)

Understanding these are important because when you are aware of these topics, you can easily account for them and improve your product. If you are creating a high-pressure tank, for example, it is helpful to consider the ideal gas law (when you compress an ideal gas, the temperature inside the tank will rise), and the ideal gas law (if the gas has too high of a compressibility factor, you might need to compensate by increasing the volume of the tank or power of the compressor).

4) The area of pneumatics engineering falls under the larger umbrella of Fluid Power. This area is so important in industry that there is a professional organization devoted to assisting and supporting engineers and manufacturing system designers in using fluid power. This organization is the National Fluid Power Association (NFPA). Their website is located at:

<http://www.nfpa.com/>

- a) Go to their website and review the various sections of their website. Describe what the NFPA sees as their mission. (2 points)

The NFPA sees education and collaboration as vital to their mission. The NFPA's goal includes educating university students and technically trained people about fluid power and connect them with careers in the field. The organization also aims to allow for effective collaboration between manufacturers, distributors, and suppliers in forum form and provide these members with industry statistics and business intelligence.

- b) Under the "What is Fluid Power?", they discuss several topics. Briefly describe these various topics. (2 points)

Under the "What is Fluid Power?" section, they discuss two topics, in particular: pneumatic power and hydraulic power. Both of these have the same general principal. They both transmit power from one location to another. However, a pneumatic system does this by means of air or gas, and hydraulic systems do this via a liquid. Hydraulic systems, in general, have the potential to be more powerful than pneumatic, but pneumatic power offers the added benefits of being clean, inexpensive, and (relatively) simpler than hydraulic. An example of a hydraulic system is the hydraulic cylinders and pump that a convertible uses to raise and lower the top, and an example of a pneumatic system can be air brakes on trains. There is a side-note on the basics of power transmission, as well.

- c) How they define pneumatics? (2 points)

The NFPA defines pneumatics as the transmission of power from one location to another using a gas.

d) They also give an example of how "a fluid pressure of 1,000 psi can push with 3140 lbs. of force. A pneumatic cylinder using 100 psi air would need a bore (diameter) of approximately 6½ in. to develop the same force." Quantitatively (by calculations) show how this is so. (2 points)

Hydraulic Cylinder:

$$\text{Area} = \pi \times \left(\frac{2.0 \text{ inch diameter (of a hydraulic cylinder, given in website)}}{2} \right)^2 = 3.14 \text{ in}^2$$
$$\text{Force} = 3.14 \text{ in}^2 \times 1,000 \text{ psi} = 3140 \text{ lb of force}$$

Pneumatic Cylinder:

$$\text{Area} = \pi \times \left(\frac{6.5 \text{ inch diameter (of a pneumatic cylinder, given in website)}}{2} \right)^2 = 33.18 \text{ in}^2$$

$\text{Force} = 33.18 \text{ in}^2 \times 100 \text{ psi} = 3318 \text{ lb of force}$

d) Go to the "Fluid Power Education & Careers" section on the upper heading of website. Under the "Students" section review, list and describe in five or six sentences each three different types of job positions and the associated responsibilities. In addition pick three companies and describe how they may use pneumatics. (3 points)

Internships, part-time, and full-time are the different types of employment opportunities available. Internships are generally geared towards learning, so the intern typically is assigned to an engineer for mentorship. Depending on the company, interns can either be given remedial tasks or more serious responsibilities, like product testing or product development. The main difference between full-time and part-time employment is the amount worked per week. Typically, part-time employees work less than 40 hours a week and full-time will work at least 40 hours per week. If anything, full-time employees are assigned more responsibility or more serious tasks. Of course, specific responsibilities will depend on the engineer's position, department, and experience level.

Companies:

1. *Eaton Corporation: Seeing as Eaton creates a large array of automotive powertrain components, I would surmise that Eaton uses pneumatics for drivetrain valves and engine management valves.*
2. *Kaman Fluid Power: Kaman creates a large variety of valves, so I would say that they use pneumatics for those.*
3. *Muncie Power Products: Muncie creates a lot of different powertrain components. I would guess that they use valves for powertrain components and engine management systems.*

Appendix B-1: Assignment B in Thermodynamics

EGE3003 Fall 2017

HW “B” on Pneumatics Engineering – 25 points

Issued: October XX, 2017

Due: October XX, 2017

Background: The area of Pneumatics Engineering is an important one for many industries involved in manufacturing, production, or material conveyance. It falls under the larger classification of “Fluid Power”. In this assignment you will learn about typical operation pressures of pneumatics systems and their relationship to ideal gas assumptions.

1) Most industrial pneumatic systems operate using standard 100 psig compressed air (available in most industrial operations). Watch the following Youtube video to understand some basics of pneumatic air compressors:

“How to Choose and Use an Air Compressor - This Old House” at www.youtube.com/watch?v=u6zddqNIIdFs

2) Two engineers are discussing if typical 100 psig compressed air used in a pneumatic driven and controlled manufacturing operation can be considered an ideal gas and, therefore, allows them to use the ideal gas law. You can assist them by referencing the compressibility factor “Z”. Use the compressibility factor Z and the information from Figure A-1 (of our course textbook) to quantitatively and computationally justify if the 100 psig shop air can, or cannot, be considered an ideal gas. (Recall that for many applications values of “Z” within the range of 0.97 to 1.03 could easily allow the use of the ideal gas law with few problems and little error.) (5 points)

2) A piston-cylinder system has the following configuration. A piston has an outer diameter of 5 cm, and slides freely within a cylinder with the same inner diameter. The cylinder is fully sealed and closed at one end and the other end is open, allowing for the movement of the piston. Initially the piston is located 1 meter from the closed end of the cylinder. Initially conditions of the air are:

$$T_1 = 26^\circ\text{C}$$

$$P_1 = 1 \text{ atmosphere}$$

a) At these initial conditions it is reasonable to use the ideal gas law. The piston, however, is then very rapidly pressed into the cylinder. No air leaves the piston-cylinder assembly. The piston is pressed quickly into the cylinder (within a fraction of a second) and locked into place. The piston movement is so rapid that the air/system can initially be assumed to be adiabatic. At this new piston position, the air temperature within the cylinder correspondingly and momentarily rises to 550°C and the air pressure increases to 100 atmospheres. At the instant of the new piston position is it still reasonable to assume the air in the cylinder is an ideal gas? Quantitatively and computationally verify this using “Z” from Figure A-2. (8 points)

b) Compute the work that was rapidly applied to the piston to move it to the new position within the cylinder. (7 points)

c) The piston and cylinder are left at the new piston position remains locked into place, and left to sit for several hours such that the temperature of the gas and the cylinder are allowed to return to the initial temperature of 26°C, but the piston does not move from the new position. Determine the pressure of the air within the cylinder under these conditions. (5 points)

Appendix B-2: Student Work Sample

AIR

$$= 28.97 \text{ kg/kmol}$$

$$T_c = 133 \text{ K}$$

$$P_c = \frac{37.76 \text{ bar}}{0.0689476} \text{ psi}$$

$$P_c = 546.792 \text{ psi}$$

$$Z_c = \frac{P_c V_c}{R T_c} = 0.284$$

$$V_c = 8.33$$

$$P_R = \frac{P}{P_c} = \frac{114.7 \text{ psi}}{546.792 \text{ psi}} = 0.209769$$

GIVEN

Absolute @ sea level

$$100 \text{ psig Air} = 100 \text{ psi} + 14.7 \text{ psi} = 114.7 \text{ psi} \left| \frac{0.0689476 \text{ bar}}{\text{psi}} \right| = 7.90829 \text{ bar}$$

$$P_R = \frac{P}{P_c} = \frac{114.7 \text{ psi}}{546.792 \text{ psi}} = 0.209769$$

$$P_R = \frac{P}{P_c} = \frac{7.90829 \text{ bar}}{37.7 \text{ bar}} = 0.209769 \quad \#5$$

Assuming $0.97 \leq Z \leq 1.03$ allows for Ideal Gas Law w/ few Problems

- Using Figure A-1 w/ $P_R = 0.209769$ & Z -values between 0.97 & 1.03 relative T_R 's can be assumed.

- T_R Values - 1.30, 1.40, 1.60, 2.00, 3.00, 5.00

For IDEAL Z 's

$$- T_R = \frac{T}{T_c} \dots T_{\min} = T_R T_c = 1.30 (133 \text{ K}) = 172.9 \text{ K} = -100.25^\circ \text{C} = -148.45^\circ \text{F}$$

$$T_{\max} = T_R T_c = 5.00 (133 \text{ K}) = 665 \text{ K} = 391.85^\circ \text{C} = 737.33^\circ \text{F}$$

Temp Range @ 100 psig is -100.25°C to 391.85°C
 172.9 K to 665 K
 -148.45°F to 737.33°F

- Very Reasonable to assume the 100 psig shop air can be considered an ideal gas within a very large range of temperatures, approx. -100.25°C to 391.85°C , for this example.

KNOWN W/ SCHEMATIC

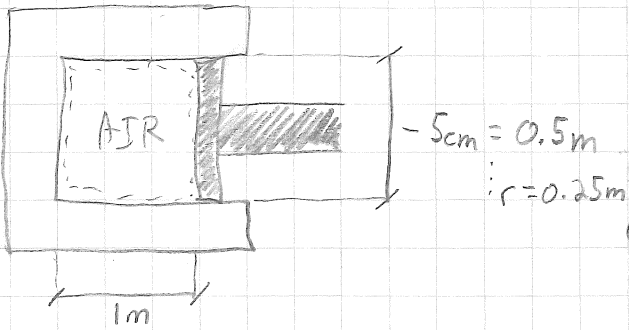

$$\begin{aligned} \textcircled{1} \quad T_1 &= 26^\circ\text{C} = 299.15\text{ K} \\ P_1 &= 1\text{ ATM} = 1.01325\text{ bar} \\ V_1 &= \pi r^2 h = \pi (0.25)^2 (1) = 0.19635\text{ m}^3 \\ \textcircled{2} \quad T_2 &= 550^\circ\text{C} = 823.15\text{ K} \\ P_2 &= 100\text{ ATM} = 101.325\text{ bar} \\ V_2 &= ? \end{aligned}$$

ASSUMPTIONS

- Closed System
- Very rapid piston compression w/ no air leaving assembly to $\textcircled{2}$
- Adiabatic; $Q = 0$

DETERMINE

- Quantitatively: computationally verify, using "z" from A-2, that at $\textcircled{2}$ position it is reasonable to assume the air in cylinder is an ideal gas.
- Compute the work that was rapidly applied to the piston to move it to the new piston within the cylinder.
- At $\textcircled{2}$ position it remains there for several hours such that temperature of the gas and cylinder are allowed to return to 26°C , but the piston does not move from the new position. Determine the pressure of the air within the cylinder under these conditions.

a) using Figure A-1 & A-2 for states $\textcircled{1}$; $\textcircled{2}$

KNOWN For Air

$$M = 28.97\text{ kg/kmol}$$

$$T_c = 133\text{ K}$$

$$P_c = 37.7\text{ bar}$$

$$\textcircled{1} \quad P_r = \frac{P_1}{P_c} = \frac{1.01325\text{ bar}}{37.7\text{ bar}} = 0.02687$$

+8

$$T_r = \frac{T_1}{T_c} = \frac{299.15\text{ K}}{133\text{ K}} = 2.24925$$

$$Z_1 \approx 0.99 \text{ by A-1 figure analysis}$$

$$\textcircled{2} \quad P_r = \frac{P_2}{P_c} = \frac{101.325\text{ bar}}{37.7\text{ bar}} = 2.69052$$

$$T_r = \frac{T_2}{T_c} = \frac{823.15\text{ K}}{133} = 6.1891$$

$$Z_2 \approx 1.035 \text{ by A-2 figure analysis}$$

a) CONCLUSION

- Given that air behaves, with few problems and little error between the z-range of 0.97 to 1.03, we can't assume that at position $\textcircled{2}$ air is an ideal gas. This assumption is based on the use of figure A-2 and the computationally and quantitatively determined compressibility factor, "z", of 1.035, that is just outside of 1.03.

adiabatic $\gamma = 1.4$ Problem doesn't state a vertical cylinder, assumed horizontal configuration.

$$W = \Delta KE + \Delta PE + \Delta U$$

$$W_{12} = \Delta U$$

$$W_{12} = -m(u_2 - u_1)$$

- Using tables A-22 for Ideal Gas Properties of Air to extrapolate or interpolate values for internal energy, u 's, for positions ① and ②

① $T_1 = 299.15 K \approx 300 K$

$u_1 \approx 214 \text{ kJ/kg}$

Mass @ assumed Ideal Gas in state ①

$$m_{air} = \frac{P_1 V_1}{RT_1}$$

② $T_2 = 823.15 K$

$u_2 \approx 611.17 \text{ kJ/kg}$

$$m_{air} = \frac{1.01325 \text{ bar} (0.19635 \text{ m}^3)}{\left(\frac{8.314 \text{ kJ/kmol} \cdot \text{K}}{28.97 \text{ kg/kmol}}\right) (299.15 \text{ K})} \times \left(\frac{10^5 \text{ N/m}^2}{\text{bar}}\right) \times \left(\frac{1 \text{ kJ}}{10^3 \text{ N} \cdot \text{m}}\right)$$

$m_{air} = 0.23174 \text{ kg}$

$$W_{12} = -0.2317 \text{ kg} (611.17 \text{ kJ/kg} - 214 \text{ kJ/kg})$$

$$W_{12} = -92.0243 \text{ kJ}$$

c) At position ③ and after temperature returns to $26^\circ C (299.15 K)$, what is the pressure within the cylinder under these conditions?

$P_c @ 299.15 K \approx 1.37254$

$P_c = 37.7 \text{ bar} + 5$

$$P_3 = P_c \cdot P_r = 37.76 \text{ bar} (1.37254)$$

$$P_3 = 51.7448 \text{ bar}$$

Assuming Air as an Ideal Gas at these conditions and using table A-22 to interpolate P_r at $299.15 K$.

Appendix C-1: Assignment in Fluid Mechanics

EME 3123 – Fluid Mechanics – Design Project
Fountain from Youth
(a.k.a. Bellagio’s Little Cousin)
Spring 2017, Section 1, Dr. Gerhart

Assigned: Thursday, March 16
Preliminary Reply: Monday, March 27
Interim Design Review Due: Monday, April 10
Final Design Due: Monday, April 24

Instructions:

You must work in a team of three of your choosing. Submit one report for the entire team. The Preliminary Reply is a list of responses by the team concerning preliminary problem solving. For the Interim Design Review, I will carefully inspect your work and make comments to improve your design and process. Then you will have time to work-out any problems or issues, fix mistakes, or alter your design. This should allow you the chance to develop a very good and practical design (assuming that you have substantial work attempted for the Interim Design). The Interim Design does not need to be typed and formal, but have it very neat so that I can clearly inspect your work. Your final design report will be typed with the format indicated below. Sample calculations can be done by hand in the appendix, but your calculation/design steps with some equations should be in the main body of the report. I also want your design explained well and readable (i.e., pay attention to presentation, clarity, and grammar). Since a design report is not the same as a homework assignment, don’t just do some calculations with a few numbers in boxes. Explain your steps and show all of your work neatly. A good design with sloppiness and poor explanation will appear like a bad design. I do grade grammar and clarity.

Format:

Abstract – This section is one paragraph or two short paragraphs that briefly describes the main components of your design. It should be a stand-alone section that reveals the major conclusions that are of interest to your customer.

Introduction – Describe the problem to be solved, objectives/goals, assumptions.

Description – Include a comprehensive schematic(s) of your final design near the beginning of this section. Then go through the design process with important calculated results and/or graphs, tables, etc. and include additional sketches and drawings if necessary. Be logical in your sequence of this section. Always title (caption) and label any figures. As common practice, any figure in the report must be discussed somewhere in the text.

Conclusion – Summarize the features of your design, the estimated cost to produce it, and the estimated yearly operational cost.

References – Use a standard format for references (e.g., APA, MLA, Chicago)

Appendix – This section is not required, but may include useful items that add detail which was not completely necessary in main body of the report. Examples include hand calculations, lengthy computer print-outs, or anything else that supports your design. Everything in the Appendix should be noted in the report. For example, “Appendix A shows the detailed calculations of the previous result.” Otherwise, the material does not belong in the Appendix and hence the report.

Fountain with Hydraulically Controlled Nozzle System

Three and half years ago, your rich uncle, Mortimer, purchased a large tract of land in the Upper Peninsula of Michigan. He did not become wealthy by purchasing worthless things, yet the land he bought has no valuable minerals, nor any profit from lumber. Instead, it has a magnificent wilderness resort lodge, which had been abandoned years ago and had fallen into a dilapidated state. The lodge is known as the Overlook Hotel. (No, not *that* Overlook Hotel from *The Shining*; that place makes people go crazy and is located in

the mountains of Colorado.) After Uncle Mortimer restored the Overlook, his guests come to enjoy forest hiking, mountain biking, and a variety of other outdoor pursuits. Some just come to enjoy the peace and quiet at the hotel. Since the Overlook is located on a rocky hillside 300 vertical feet above the lake (which is what the hotel “overlooks”) and 2200 ground feet from the lake’s edge, he installed a chair lift for downhill skiing to draw customers during the brutally cold winter months. He has also installed a surface called “Snowflex” so that skiers can enjoy the slopes in both summer and winter. Yet with all that, there is one more element that Uncle Mort feels would really enhance his hotel: a mesmerizing fountain display. He has seen the fabulous Bellagio Fountains, and enjoys the interesting fountain in the McNamara Terminal of the Detroit Metropolitan Airport. He wants something that will be appropriate for his wilderness resort.

After learning of your vast new knowledge of fluid mechanics, he has asked you to design a fountain. As a member of the National Fluid Power Association, Uncle Mort requires that one or more of the nozzles is controlled by a hydraulic system which will allow the nozzle(s) to move the water jet(s) in some sort of pattern. The water jet(s) from the movable nozzle(s) must be high enough pressure to allow for a sufficient water height. He wants this fountain to be an attraction for his customers. You will need to consider a water delivery system, filter(s), a piping system, hydraulic system, and other components for this fountain. You must keep in mind that Uncle Mortimer is miserly with his expenses; he did not get rich by wasting money. But Uncle Mortimer is very generous with his family. Therefore if you can design an efficient and cost effective system, you will not only be paid well, you will likely inherit the land and hotel in Uncle Mortimer’s will!

Preliminary Reply Investigation: some (not all) considerations during the first ten days. If necessary, consult your customer.

- What major components are needed for a fountain and a hydraulically controlled device?
- Where will the fountain be located?
- What should be the overall footprint size of the fountain?
- When and/or how often is the fountain operational?
- What intriguing display features should the fountain exhibit, and how many nozzles does that require? How many of those nozzles are hydraulically controlled?
- What items have a significant cost for operation?

Some considerations:

- Ensure that the fountain has sufficient water flow and pressure.
- Be careful with pipe selection (sizing) and material, ensuring that the water is fairly equally distributed throughout the area based on the display options. Carefully consider the layout of the water system so as not to overcomplicate the problem.
- Be cautious that the components and design are not too costly. You should keep track of approximate expenses for components, and keep notes of how you kept costs down. Uncle Mort will want to know. You do not need to consider installation costs, unless your design plan is especially unique. (Consult your customer to determine if installation costs are required for your plan.)
- Include operational expenses for Uncle Mortimer. In other words, choose your water delivery system wisely. What will it cost per year to run the water operation?
- You are designing the fluid system and hydraulic system only, not any potential electronic control system, and not the solid structure of the pool, pipe/pump support, etc. On the other hand, you must consider forces from the nozzles (as per the hydraulic system requirements). You will also have to consider placement of the various components and, of course, sizes.
- Be careful with all fluid components sizing (pipes, pumps, etc.). Do not drastically oversize or undersize your pump(s).
- Valves....
- The hillside continues above the lodge another 400 vertical feet to the summit in 600 ground feet.

Appendix C-2: Student Work Sample

Fluid Mechanics - Design Project
Fountain from Youth
Final Design Report

see page 10 for R.O.I.

75
/
80

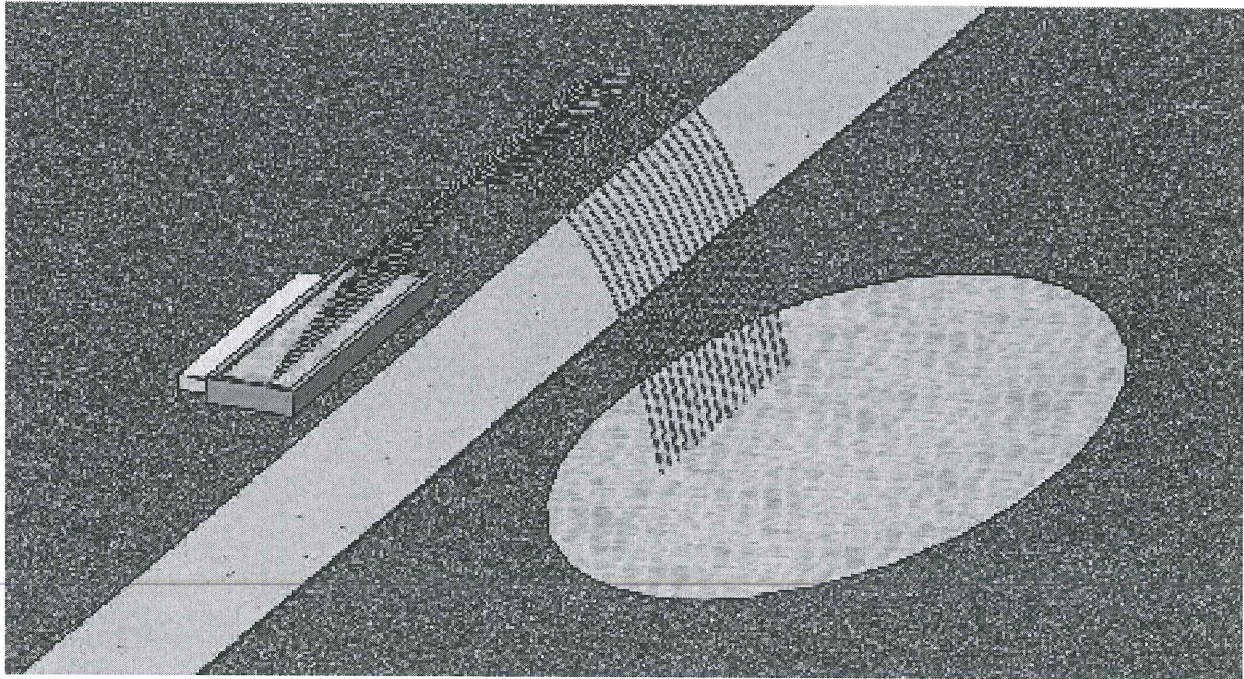

I have neither given nor received unauthorized aid in completing this work, nor have I presented someone else's work as my own.



Abstract

This report covers the design considerations for a fountain display for the Overlook Hotel in Michigan's Upper Peninsula. The proposed fountain at the Overlook Hotel is to add to the Hotel's aesthetics and if possible help increase business as a tourist attraction similar to the Bellagio Fountain. The proposed design consists of a sixteen-nozzle system powered by four pumps that create a tunnel of water jets shooting over 50ft across the entrance road leading up to the hotel. The nozzles will be controlled by a hydraulic system that allows for the direction of the jets to vary in order to create patterns. The overall installation of the fountain is estimated at \$64,419.78, with an annual operation cost of \$21,000 if the fountain is run sixteen hours per day from May to November. Although the cost of the fountain is relatively expensive it will become an instant attraction in Michigan's Upper Peninsula adding to the value and marketability of the Overlook Hotel.

Introduction

The problem that was posed by Uncle Mortimer was to design a display fountain system for his “Overlook Hotel” that is located in the Upper Peninsula. A variety of constraints were placed on the project, which mainly involved keeping the project efficient and relatively cost conscious. The goals for this project aligned with Uncle Mortimer’s desires, since we designed a fountain that has a large attractive value while keeping costs relatively low in comparison to other large fountain displays. In order to complete the calculations on such a project, several assumptions were made during the design and calculation stages. Firstly, it was assumed that the density of the water remained at the 70 degree fahrenheit value, even though the fountain will likely operate at higher and much lower water temperatures. Also, the addition of a pond was assumed to be feasible, even though adding a large pond in front of the hotel may not be an option due to the large space needed for it. Finally, other more specific calculation based assumptions were made, which can be found in the section in which they apply.

Description

Design Overview

The proposed fountain would be located in front of the hotel alongside the entrance road leading up to the resort, and will shoot water jets across the roadway into an adjacent pond as seen in Figure 1 below.

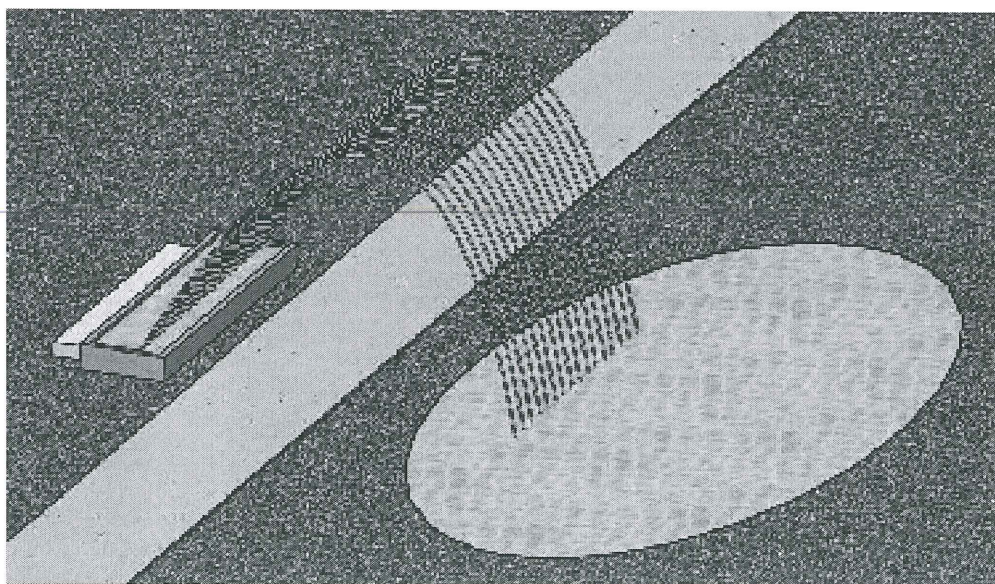

Figure 1: Rendering of the proposed fountain design.

Dimensions of the pond will be roughly 140x60 feet and 8 feet deep. The fountain basin itself will be 50x10x3 feet, with a system of 16 nozzles spaced 3.125 feet apart from each other. The water jets from the fountain travel 55 feet horizontally across the road into the pond, and will reach a height of about 8.48 meters, or 27.8 feet high when shot at a 45° angle. In order to pressurize the water entering the nozzles, four pumps will be used with each pump feeding four of the nozzles. It is important to note that all the calculations referenced in the “description” section of this report are for only one of the four individual pump/nozzle systems. As stated, each one of these pump/nozzle subsystems has one pump and four nozzles. This means that the components and associated values found in this section would need to be quadrupled in order to find the total fountain values. All of the calculations were done on a single pump/nozzle subsystem in order to simplify the numbers and understanding of the design.

Nozzle Selection

The Fontana MJ300 nozzle was selected for its ability to produce the desired spray height (10m max height), while also creating a thicker water jet than a standard nozzle due to its hollow jet design. This hollow water jet uses much less water than a solid jet, making it a great choice for a fountain like this because it allows for the use of a smaller system to support the nozzle flow. This specific nozzle comes equipped with an integrated ball joint, allowing for the direction of the flow to not only be adjusted via the hydraulic control system during operation, but to also be aimed at a constant 45 degree angle over the road. Fontana Fountains website supplies the head loss and flow rate required to reach the desired height of spray. In order to select the nozzle, the required horizontal water distance (R) was first determined to be about 56 feet. Using the following projectile motion equation and an angle of 45 degrees:

$$R = \frac{V_o^2 \sin 2\theta}{g}$$

a velocity value of 42.3 ft/s is calculated. This nozzle exit velocity was then used to calculate the required vertical water height (H) using this equation:

$$H = \frac{V_o^2 \sin^2 \theta}{2g}$$

After calculating the required vertical height (27.8 feet) the nozzle must shoot water in order to cover the necessary distance, a nozzle could be selected. According to the Fontana Fountains website, the MJ300 has the capability to produce the targeted distances, and requires 13.7 m of

head and 731 Lpm of flow. This flow value was then multiplied by four since each pump must feed four nozzles. Afterwards, the total pressure and flow rate that needed to be supplied to four nozzles was 19.5 PSI and 772 GPM.

System Losses

In order to determine the size of pump needed for the system, the pressure drop through the pipes needed to be calculated. This pressure would then be added to the amount of pressure needed at the nozzle which was provided by the manufacturer. When calculating the losses in the pipes it was decided that using head loss would simplify the calculations because it could be converted directly into pressure afterwards. In order to determine the head loss several unknowns first had to be found. The following equation was used to calculate head loss.

$$\text{Head Loss} = f \left(\frac{L}{D} \right) \left(\frac{V^2}{2g} \right) + K_L \frac{V^2}{2g}$$

^{major}
 ~~$(?)$~~ ✓ used equiv. length later.

The constant f was found using a ~~M~~ moody chart. In order to determine f , the value of the Reynolds number as well as ϵ/D was needed. Since polyvinyl chloride (PVC) was chosen as the pipe material due to its low cost and high durability, the relative roughness value can be assumed to be zero. The Moody Chart was then used to determine the friction factor that corresponds with the calculated Reynolds Number and relative roughness. The calculated values for Reynolds numbers can be found below in Table 1.

Table 1: Calculated values for the various tubing sizes and lengths.

Section	Re	Area (ft ²)	Diameter (ft)	f	Length (ft)	L/D	gh _L (ft ² /sec ²)	h _L (ft)
6"	3.6E ⁵	0.196	0.5	0.013	222.5	453	226.2	7.03
5"	2.2E ⁵	0.136	0.417	0.0155	90.85	218	67.4	2.10
3"	1.8E ⁵	0.049	0.25	0.016	46.65	186.6	114.0	3.54
						Total	408	12.7
							Pressure Drop	5.5 psi

I don't understand these lengths? Figure 2 shows much smaller lengths. (maybe these include leg?) 0.3

After designing the system shown in Figure 2, below, the appropriate length of pipe was measured and the equivalent length for the various fittings were obtained from the table found in Appendix A.

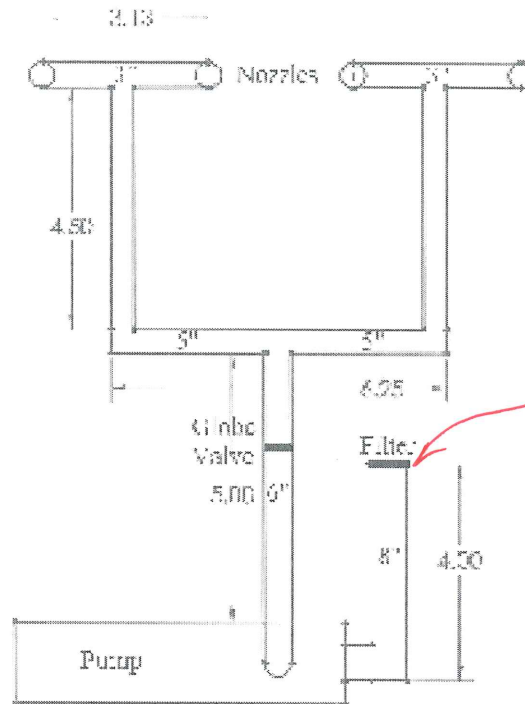

Are you recirculating water from pond? If so, those pipes must also be considered for pump sizing. (2)

Figure 2: Piping layout diagram for one pump/nozzle subsystem. Piping length is measured in feet and piping diameter is measured in inches as indicated. All length dimensions were found using the Solidworks rendering as a model.

The equivalent length values of the various components allowed us to calculate the losses from the fittings, bends, tees, and valves. Adding the true length to the equivalent length yielded the effective length to use in the head loss equation. The velocity of the flow was calculated using flow rate and cross sectional area of the pipe. Due to the design of the system the head loss, h_L of the pipes had to be calculated in several sections based on the flow rates, as the water flow branched off several times, and the diameter of the pipe sections varied. Three sections were used while calculating h_L for this system, with one section for each time the flow split. The calculated h_L value was then converted ~~converted~~ into pressure in units of PSI. Table 1, above, shows the variables used and the h_L , gh_L , and pressure drop value along with the constants used for the calculations.

Pump and Filter Selection

A centrifugal pump was chosen for this application due to its relatively small size, simplicity, and availability. After calculating the pressure loss through the pipes and adding it to the pressure required at the nozzle, the total pressure that the pump must supply was determined. As mentioned previously, the head required by the nozzle was supplied by the manufacturer, Fontana Fountains. By adding the manufacturer's value to the total h_L in Table 1, the total head value could be calculated. In order to assure that the pump could always supply the nozzle's required pressure and flow rate, both the head loss and flow rate values were arbitrarily increased to 50 ft and 800 GPM, respectively. From Figure 4, below, the data for the chosen R6FL15 can be observed.

from 79 ft?
from 772 gpm?
(Really this should be "Table 1")
this should work ... instead of this

Basic Pump Model	Motor HP	Disc. Size	Suct. Size	TOTAL HEAD IN FEET													Shut-Off Head Feet	
				20	25	30	35	40	45	50	55	60	65	70	75	80		
R6FL5	5	6	8	810	720	600	420	110										41
R6FL75	7½	6	8	1000	960	905	840	735	580	270								54
R6FL10	10	6	8		1070	1025	960	890	805	680	440	100						61
R6FL15	15	6	8					1165	1120	1065	1000	910	800	630	300			78
R6FL20	20	6	8						1250	1210	1160	1105	1040	950	840	660		89
R6FM10	10	6	8	1200	1150	1070	980	860	700	480								55
R6FM15	15	6	8			1365	1305	1240	1160	1080	960	780	460					68
R6FM20	20	6	8					1445	1385	1320	1250	1170	1080	920	680			80
R6FM25	25	6	8						1525	1480	1420	1345	1260	1155	1020	820		89

Figure 3: Total head vs flow rate for the R6FL series of centrifugal pumps.

The R6FL15 has the capability to supply more than the necessary pressure and flow rate, therefore a globe valve was placed on the pump outlet in order to throttle back the flow. Although the globe valve is very detrimental in regards to its contribution to the head loss, it allows for greater control over the water jet distance than other less intrusive valve designs.

The filter for this system is rather robust due to the high flow rate that it must be able to support. The industrial style basket strainer filter is attached to the 8 inch PVC intake pipe through a PVC-to-flange adapter. This filter uses a 40 mesh screen, which is the standard filtration size for many industries. The purpose of the filter is to prevent any pond debris from entering the expensive pump system, which could cause damage. The pressure loss from this filter is surprising low, at only 0.73 feet of head loss. This equates to about 0.32 psi loss from the filter, which is minimal enough to be ignored. This calculation was done using the manufacturer supplied equations (which can be found on IFC's website) and chart (which is supplied in Appendix B).

Hydraulic Control System

The Hydraulic System for the fountain oscillates the nozzles back and forth using a hydraulic cylinder with a stroke of 1 inch. This will be split 50/50 so that the stroke goes .5 inches in the positive and negative direction. The nozzles will oscillate 10° to either side from the vertical position. In order to achieve this design goal, a rod will be connected to all 16 nozzles at 2.85 inches from the pivot point. This geometry gives an oscillation angle of 9.95° in each direction. One hydraulic cylinder and pump was used to reduce the complexity of the system. The hydraulic cylinder that will be used is a 1.125x1x0.3125 Hydraulic/pneumatic cylinder capable of a maximum working pressure of 500 PSI. The bore of the cylinder is 1.125 inches, which allows the cylinder to supply a maximum force of almost 500 lbs. The force required to hold the 16 nozzles at a 10 degree angle was calculated to be 7 lbs per nozzle, or 112 lbs total. This calculation was done by finding the force on the nozzle in the x direction, using the basic momentum equation.

$$F = \sum_{out} \rho V A(V) - \sum_{in} \rho V A(V)$$

The pressure for the hydraulic cylinder will be provided by a Vac Haldex Barnes powerpack which is capable of 150-1350 psi of pressure. The system will be controlled by a Northman Fluid Power Hydraulic Directional Control Valve which is a three position directional control valve. This control valve will electronically control the oscillation motion of the nozzles, while also being able to hold the nozzles at the neutral (straight over the road) position. The hydraulic schematic combined with the full fountain schematic can be found in figure 4, which is pictured on the following page.

(0.5)
Difficult to understand.
The nozzles at neutral are 45°.
So what is 10° from vertical?
seems like an overly expensive choice.

Conclusion

The proposed final fountain design in total is composed of approximately 122 feet of straight schedule 40 PVC pipe, pipe fittings, sixteen MJ300 hollow jet nozzles, four 15 HP Griswold R6FL15 pumps, a Northman Fluid Power Hydraulic Directional Control Valve, a Haldex Barnes power supply, hydraulic cylinder and hydraulic hose. The total estimated cost of the components is \$60,119.78. Refer to Table 2 below for a more comprehensive overview of the system components, and a breakdown of the cost for each individual part. Installation cost for the 8400 square-foot pond is estimated to be \$4,300. This cost is based on the cost of other similarly sized ponds that have recently been constructed. With the addition of the pond, the overall material cost of the entire fountain system is \$64,419.78.

Table 2: Breakdown of cost per unit for each component

Part	Unit Cost	# Units Required	Total Cost
6" Elbow	\$20.42	4	\$81.68
5" Elbow	\$16.50	8	\$132.00
5" X 3" Reducer	\$51.22	16	\$819.52
5" Tee	\$22.88	12	\$274.56
Griswold R6FL15 Pump	\$4,546.50	4	\$18,186.00
MJ300 Hollow Jet Nozzle	\$1,230	16	\$19,680.00
Filter	\$3,700	4	\$14,800.00
Spears 6" PVC Globe Valve	\$1,216.55	4	\$4,866.20
Hydraulic Cylinder	\$39.95	1	\$39.95
Hydraulic Power Unit	\$329.95	1	\$329.95
Directional Control Valve	\$119.99	1	\$119.99
Hydraulic Hose	\$1.83	10	\$18.30
Pipe Diameter	Cost Per Foot	Length Required (ft)	
3"	\$2.48	25	\$62.05
5"	\$6.69	61	\$407.97

If you reduce pipe down (and then back up if necessary) you could save about \$900, with likely no change to pump size.

Did you consider ~~one~~ single pump size needed to run all 16 nozzles. This could potentially drop price by ~\$5000 or more.

(2)

6"	\$7.59	20	\$151.76
8"	\$9.37	16	\$149.86
			\$60,119.78

Given that the current cost of electricity for a small commercial application in Michigan is \$0.12/kWh, then the pumps running at full capacity will cost \$5.4 per hour. Assuming that the fountain will run 16 hours a day (8:00am-12:00am) from May to the beginning of November, the estimated annual running cost will be approximately \$21,000.

Although this fountain does seem expensive in comparison to some of the smaller display fountains, it is indeed competitive with the medium sized display fountains found at other hotels and airports. We believe that this display will be a great attraction to add to the hotel. Being able to drive under the water streams of the fountain is a unique design detail not seen in many fountains today. At night time, the experience of driving under the water would be even greater, especially if lights are added to illuminate the inside of the hollow water streams. Ideally, this feature will bring photographers and other visitors to the location to experience the fountain and the rest of the resort.

Return on investment: raise room cost \approx \$5/night.

*Summer \rightarrow \$45,000 extra.
50 rooms*

*-\$21,000
\$24,000/year*

$\frac{60,120}{24000} \Rightarrow$ paid off in 2.5 years

References

- (2017). Retrieved 24 April 2017, from <https://www.clearpond.co.nz/wp-content/uploads/pdfs/OASE%20FT%20Catalogue%202016.pdf>
- (2017). Retrieved 24 April 2017, from <http://www.psgdover.com/assets/griswoldpump/downloads/brochures/Griswold-E-F-G-Brochure.pdf>
- (2017). Retrieved 24 April 2017, from http://islipflowcontrols.com/images/products/brochures/castsimplex/SimplexStrainer_cat_14-17.pdf
- (2017). Retrieved 24 April 2017, from http://islipflowcontrols.com/images/products/brochures/castsimplex/SimplexStrainers_cat.pdf
- (2017). Retrieved 24 April 2017, from http://islipflowcontrols.com/images/products/brochures/castsimplex/SimplexStrainers_cat.pdf
- (2017). Retrieved 24 April 2017, from http://www.pipeflow.co.uk/public/articles/Viscosity_And_Density_Units_And_Formula.pdf
- Converting Pump Head to Pressure and Vice Versa.* (2017). *Engineeringtoolbox.com*. Retrieved 24 April 2017, from http://www.engineeringtoolbox.com/pump-head-pressure-d_663.html
- End Suction Centrifugal - PSG Dover.* (2017). *Psgdover.com*. Retrieved 24 April 2017, from <http://www.psgdover.com/en/griswold/products/end-suction-centrifugal>
- Hollow Jet - Stainless Steel Fountain Nozzle - Fontana Fountains.* (2017). *Fontana*. Retrieved 24 April 2017, from <http://www.fontanafountains.com/products/spray-systems/fountain-nozzles-heads/hollow-jet>
- HYDRAULAX TOUGH Hydraulic Hose.* (2017). *Discounthydraulichose.com*. Retrieved 24 April 2017, from http://www.discounthydraulichose.com/HYDRAULAX_TOUGH_Hydraulic_Hose_s/351.htm

Northman Fluid Power Hydraulic Directional Control Valve – 16.8 GPM, M. (2017). *Northman Fluid Power Hydraulic Directional Control Valve - 16.8 GPM, 4500 PSI, 3-Position, Double Solenoid, Float Center Spool, 12 Volt DC Solenoids, Model# SWH-G02-C4-D12-10 | Power Solenoid| Northern Tool + Equipment. Northerntool.com.* Retrieved 24 April 2017, from http://www.northerntool.com/shop/tools/product_200329577_200329577

OASE Pice list part number 50939 to 53056. (2017). *Comnur.com.* Retrieved 24 April 2017, from http://www.comnur.com/oase_Fountain_price_List_50939_to_53056.htm

R6FL15-TD - 9307-3153. (2017). *Pumpbiz.com.* Retrieved 24 April 2017, from <http://pumpbiz.com/r6fl15-td-9307-3153>

Schlicht, S. (2017). *how much does it cost to dig a pond.* *Pondperfection.com.* Retrieved 24 April 2017, from <http://www.pondperfection.com/blog-pond-clean-out-Mich/bid/51410/how-much-does-it-cost-to-dig-a-pond>

Schlicht, S. (2017). *how much does it cost to dig a pond.* *Pondperfection.com.* Retrieved 24 April 2017, from <http://www.pondperfection.com/blog-pond-clean-out-Mich/bid/51410/how-much-does-it-cost-to-dig-a-pond>

Water - Dynamic and Kinematic Viscosity. (2017). *Engineeringtoolbox.com.* Retrieved 24 April 2017, from http://www.engineeringtoolbox.com/water-dynamic-kinematic-viscosity-d_596.html

Water - Specific Volume and Weight Density. (2017). *Engineeringtoolbox.com.* Retrieved 24 April 2017, from http://www.engineeringtoolbox.com/water-specific-volume-weight-d_661.html

Appendix A

Friction Loss of Water in Pipe Fittings in Terms of Equivalent Length - Feet of Straight Pipe																
Nominal pipe size	Actual inside diameter inches d	Friction factor f	Gate valve - full open	90° elbow	Long radius 90° or 45° std elbow	Std tee - thru flow	Std tee - branch flow	Close return bend	Swing check valve - full open	Angle valve - full open	Globe valve - full valve	Butterfly valve	90° Welding elbow		Mitre bend	
													r/d =	r/d =	45°	90°
½	.622	.027	.41	1.55	.83	1.04	3.11	2.59	5.18	7.78	17.6					
¾	.824	.025	.55	2.06	1.10	1.37	4.12	3.43	6.86	10.3	23.3					
1	1.049	.023	.70	2.62	1.40	1.75	5.25	4.37	8.74	13.1	29.7					
1¼	1.380	.022	.92	3.45	1.84	2.30	6.90	5.75	11.5	17.3	39.1					
1½	1.610	.021	1.07	4.03	2.15	2.68	8.05	6.71	13.4	20.1	45.6					
2	2.067	.019	1.38	5.17	2.76	3.45	10.3	8.61	17.2	25.8	58.6	7.75	3.45	2.07	2.58	10.3
2½	2.469	.018	1.65	6.17	3.29	4.12	12.3	10.3	20.6	30.9	70.0	9.26	4.12	2.47	3.08	12.3
3	3.068	.018	2.04	7.67	4.09	5.11	15.3	12.8	25.5	38.4	86.9	11.5	5.11	3.07	3.84	15.3
4	4.026	.017	2.68	10.1	5.37	6.71	20.1	16.8	33.6	50.3	114	15.1	6.71	4.03	5.03	20.1
5	5.047	.016	3.36	12.6	6.73	8.41	25.2	21.0	42.1	63.1	143	18.9	8.41	5.05	6.31	25.2
6	6.065	.015	4.04	15.2	8.09	10.1	30.3	25.3	50.5	75.8	172	22.7	10.1	6.07	7.58	30.3
8	7.981	.014	5.32	20.0	10.6	13.3	39.9	33.3	63.3	99.8	226	29.9	13.3	7.98	9.98	39.9
10	10.02	.014	6.68	25.1	13.4	16.7	50.1	41.8	81.8	125	284	29.2	16.7	10.0	12.5	50.1
12	11.938	.013	7.96	29.8	15.9	19.9	59.7	49.7	99.7	149	338	34.8	19.9	11.9	14.9	59.7
14	13.124	.013	8.75	32.8	17.5	21.8	65.6	54.7	109.7	164	372	38.3	21.8	13.1	16.4	65.6
16	15.00	.013	10.0	37.5	20.0	25.0	75.0	62.5	125.0	188	425	31.3	25.0	15.0	18.8	75.0
18	16.876	.012	16.9	42.2	22.5	28.1	84.4	70.3	140.3	210	478	35.2	28.1	16.9	21.1	84.4
20	18.814	.012	12.5	47.0	25.1	31.4	94.1	78.4	156.8	235	533	39.2	31.4	18.8	23.5	94.1
24	22.628	0.12	15.1	56.6	30.2	37.7	113	94.3	188.6	283	641	47.1	37.7	22.6	28.3	113
30	28	.011	18.7	70	37.3	46.7	140	117	234.3				46.7	28	35	140
36	34	.011	22.7	85	45.3	56.7	170	142					56.7	34	43	170
42	40	.010	26.7	100	53.3	66.7	200	167					66.7	40	50	200
48	46	.010	30.7	115	61.3	76.7	230	192					76.7	46	58	230
L/D			8	30	16	20	60	50	½ to 6 = 100 24 to 48 = 50	150	340		20	12	15	60

Appendix B

Flanged Basket Strainer Pressure Drop - Liquids (Sizes 2 - 24)

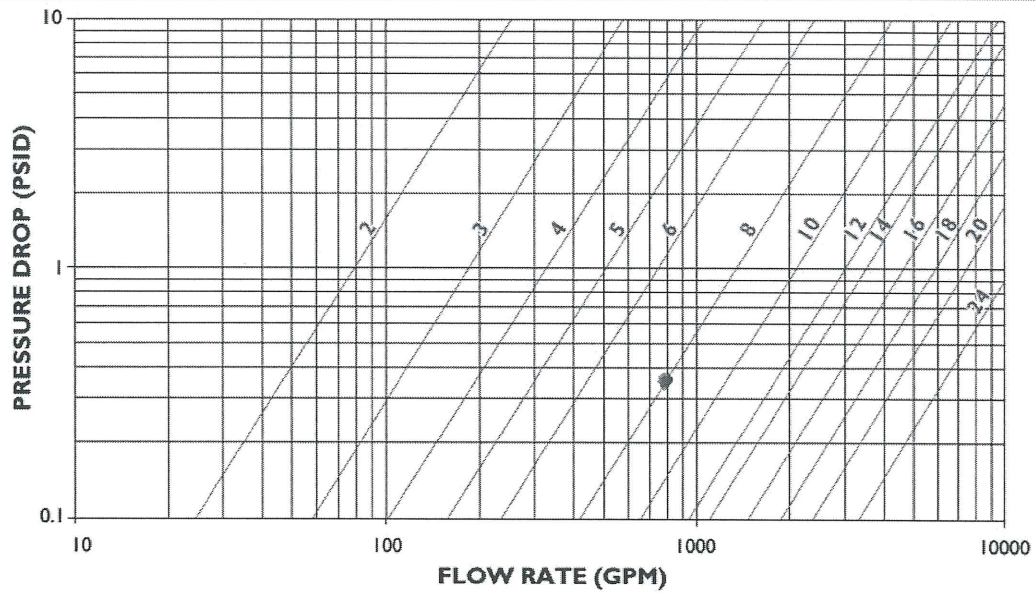

FIGURE 2

Appendix D: Pre & Post Survey

Appendix E: Entrepreneurial Minded Learning (EML) Survey

Lawrence Technological University
EME 3123 Fluid Mechanics
Project Evaluation

The following survey is used purely for assessment. The goal of this survey is to assess the project activities. It will remain confidential and will not contribute to your grade. Please answer the statements below as honestly and fairly as you can. There are no right or wrong answers, only honest ones.

Circle your response for each statement.

My project design satisfied the customer's needs and goals.

strongly disagree	disagree	no opinion	agree	strongly agree
1	2	3	4	5

I consider the results of my project successful.

strongly disagree	disagree	no opinion	agree	strongly agree
1	2	3	4	5

I found my work on the project to be satisfying.

strongly disagree	disagree	no opinion	agree	strongly agree
1	2	3	4	5

The real-world application of the project motivated me to do my best work.

strongly disagree	disagree	no opinion	agree	strongly agree
1	2	3	4	5

The open-ended nature of the project motivated me to do my best work.

strongly disagree	disagree	no opinion	agree	strongly agree
1	2	3	4	5

During the course of this project, to what extent did you:

Explore a contrarian view of accepted (i.e., typical) solutions.

None at all	slightly	on some occasions	many times	throughout most of the project
1	2	3	4	5

Identify an unexpected opportunity for your design.

None at all	slightly	on some occasions	many times	throughout most of the project
1	2	3	4	5

Create extraordinary value for a customer or stakeholder.

None at all	slightly	on some occasions	many times	throughout most of the project
1	2	3	4	5

Integrate information from many sources to gain insight.

None at all	slightly	on some occasions	many times	throughout most of the project
1	2	3	4	5

Assess and manage risk (i.e., include contingency plans due to unforeseen design flaws).

None at all	slightly	on some occasions	many times	throughout most of the project
1	2	3	4	5

Persist through failure.

None at all	slightly	on some occasions	many times	throughout most of the project
1	2	3	4	5

Apply creative thinking to ambiguous problems.

None at all	slightly	on some occasions	many times	throughout most of the project
1	2	3	4	5

Apply systems thinking to complex problems.

None at all	slightly	on some occasions	many times	throughout most of the project
1	2	3	4	5

Evaluate economic drivers.

None at all	slightly	on some occasions	many times	throughout most of the project
1	2	3	4	5

Examine a customer's or stakeholder's needs.

None at all	slightly	on some occasions	many times	throughout most of the project
1	2	3	4	5

Understand the motivations and perspectives of others.

None at all	slightly	on some occasions	many times	throughout most of the project
1	2	3	4	5

Convey engineering solutions in economic terms.

None at all	slightly	on some occasions	many times	throughout most of the project
1	2	3	4	5

Substantiate claims with data and facts.

None at all	slightly	on some occasions	many times	throughout most of the project
1	2	3	4	5

To what extent did you work with your team:

almost never	rarely	sometimes	often	almost always
1	2	3	4	5

This project improved my technical skills in:

Identifying the components and functions of a pipe system.

strongly disagree	disagree	no opinion	agree	strongly agree
1	2	3	4	5

Identifying the components and functions of a hydraulic system.

strongly disagree	disagree	no opinion	agree	strongly agree
1	2	3	4	5

Making reasonable simplifying assumptions.

strongly disagree	disagree	no opinion	agree	strongly agree
1	2	3	4	5

Analyzing the functions of various flow components (pumps, valves, etc.)

strongly disagree	disagree	no opinion	agree	strongly agree
1	2	3	4	5

Identifying and determining major and minor losses in a flow system.

strongly disagree	disagree	no opinion	agree	strongly agree
1	2	3	4	5

Predicting pressure and pipe size for series piping systems.

strongly disagree	disagree	no opinion	agree	strongly agree
1	2	3	4	5

Determining the required pumping power according to flow requirements.

strongly disagree	disagree	no opinion	agree	strongly agree
1	2	3	4	5

Choosing an actual pump that meets the flow requirements.

strongly disagree	disagree	no opinion	agree	strongly agree
1	2	3	4	5

Designing a real-world fluid mechanics system.

strongly disagree	disagree	no opinion	agree	strongly agree
1	2	3	4	5

Reporting the solution to a customer.

strongly disagree	disagree	no opinion	agree	strongly agree
1	2	3	4	5

What did you like (or appreciate) about the project?

What should be changed?

Additional comments/observations

Appendix F: Problem-Based Learning (PBL) Rubric

Problem Based Learning Rubric

Team: _____

Project/Assignment: _____

<i>Criteria</i>	1 <i>No Demonstration</i>	2 <i>Attempted Demonstration</i>	3 <i>Partial Demonstration</i>	4 <i>Proficient Demonstration</i>	5 <i>Sophisticated Demonstration</i>
Identification of Problem	No attempt to identify a problem	Poses a question for inquiry	Formulates a question with a plan for inquiry that identifies skills, knowledge, people, tools, or other resources associated with the solution	Formulates a question with a plan for inquiry that details the skills, knowledge, people, tools, and other resources needed to answer the question	Formulates a compelling question with a plan for inquiry that details the skills, knowledge, people, tools, and other resources from two or more disciplinary perspectives
Data Collection	No attempt to record data	Records and/or references observations, concepts, or details from primary or secondary sources	Records, interprets, and/or references observations, concepts, and details from primary and secondary sources	Applies standards to properly record, interpret, and reference relevant observations, concepts, and details from primary and secondary sources	Consistently applies high standards to properly record, interpret, and reference relevant observations, concepts, and details from primary and secondary
Representing Data	No attempt to represent data	Data is poorly represented in written or graphic form	Data is represented in written or graphic form using technical terms	Data is represented in written or graphic form using appropriate technical terms appropriate to the field	Data across a variety of disciplines is synthesized in written or graphic form using appropriate technical terms appropriate to the field
Verify and evaluate information	Makes no attempt to evaluate resources or data	Attempts to evaluate some resources but draws no reasonable conclusions	Evaluates some resources and data OR evaluates data and resources but draws incomplete or inaccurate conclusions	Evaluates resources and data accurately, considering credibility of sources, verification of findings, and reasonableness	Evaluates and verifies resources and data by generating original data to compare with others' findings OR by locating additional primary sources
Draw conclusions and make appropriate applications	Makes no attempt to draw conclusions or make appropriate applications	Attempts to draw conclusions from research or data analysis but they are inaccurate or irrelevant to the project	Draws some conclusions that are accurate or relevant to the project and/or uses some of the information appropriately in planning and carrying out activities	Draws accurate conclusions that are relevant to the project from research or data analysis AND uses the information appropriately in planning and carrying out activities	Draws accurate, relevant conclusions from research or data analysis and uses the information to justify and applies them in a sophisticated manner.
Justify and support decisions, strategies, findings and solutions	No explanation or justification of decisions, strategies, findings and/or solutions	Explanation used to justify and explain decisions, strategies, findings and/or solutions is not relevant to the project	Explanation used to justify and explain decisions, strategies, findings and/or solutions is not connected to the information gathered while completing the project OR is incomplete	Explanation used to justify and explain decisions, strategies, findings and/or solutions is complete and is supported by evidence gathered while completing the project	Explanation used to justify and explain decisions, strategies, findings and/or solutions is complete and is supported by evidence gathered while completing the project in a sophisticated manner.
Purpose	No product	Unclear purpose or main idea	Communicates and identifiable purpose and/or main idea for audience	Achieves a clear and distinct purpose for a targeted audience and communicates main ideas with effectively used techniques to introduce and represent ideas and insights	Achieves a clear and distinct purpose for a targeted audience and communicates main ideas with a variety of techniques to introduce and represent ideas and insights
Organization	No product	Organization is unclear; introduction, body, and/or conclusion are underdeveloped, missing, or confusing	Organization is occasionally unclear; introduction, body, and/or conclusion are underdeveloped,	Organization is clear and easy to follow; introduction, body, and/or conclusion are defined and aligned with purpose	A clear organizational structure enhances audience understanding; introduction, body, and conclusion are well defined, effective, and aligned with purpose
Detail	No Product	Supporting details and/or visuals are missing, irrelevant, inaccurate, or inappropriate	Supporting details and/or visuals are relevant but limited, overly general, or inconsistently provided	Relevant use of supporting details e.g. analogies, comparisons, examples, descriptions, AND/OR visuals e.g. symbols, diagrams, graphs, tables, maps, models	Uses a variety of clear, pleasing, and relevant supporting details that contribute to the audience's understanding

Problem Based Learning Rubric

Additional Rubric Options:

Research Rubric					
Variety of Sources	No attempt to collect data	Collects qualitative or quantitative information from primary or secondary sources	Uses technology to identify and collect qualitative or quantitative information from primary and secondary sources	Uses technology to identify and collect qualitative and quantitative information from a variety of primary and secondary sources, e.g., print, archival, observation, survey and/or interview	Uses technology to identify and collect qualitative and quantitative information across a variety of disciplines from a variety of primary and secondary sources, e.g., print, archival, observation, survey and/or interview
Validity of Data	No attempt to evaluate data	Information is recognized as fact, opinion, or generalization	Information is current and recognized as fact, opinion, or generalization	Information is current and accurate and differentiated by fact, bias, opinion, or generalization	Information across a variety of disciplines is current and accurate and differentiated by fact, bias, opinion, or generalization
Communication Rubric (suggested if students are required to write a paper)					
Language Mechanics and Usage	No product	Limited variety of sentence structures and lengths; significant errors in grammar, word usage, spelling, capitalization, punctuation, and/or pronunciation	Limited variety of sentence structures and lengths or significant errors in grammar, word usage, spelling, capitalization, punctuation, and/or pronunciation	Variety of sentence structures and lengths and no significant errors in grammar, word usage, spelling, capitalization, punctuation, and/or pronunciation	Engaging variety of sentence structures and lengths; grammar, word usage, spelling, capitalization, punctuation, and/or pronunciation almost or entirely correct
Voice	No product	Some use of descriptive language and wording that may appear mundane, forced, or awkward	Use of descriptive language or wording to communicate a personal style	Effective use of descriptive language and transitional devices to express a personal style with a discernable voice and to enhance and connect ideas	Consistent and effective use of descriptive language and transitional devices that move, engage, or teach the audience
Personal, Social, and Civic Rubric (Social is recommended if students are working in teams)					
Personal	Unaware of responsible personal behavior	Recognizes responsible personal behavior but is unable to explain its importance in a physical activity setting	Able to explain responsible personal behavior but is unable to demonstrate it consistently in a physical activity setting	Able to explain and demonstrate responsible personal behavior in a physical activity setting, including safe and appropriate etiquette and conduct	Able to explain the importance and impact of responsible personal behavior in society
Social	Unable to recognize a competent leaders and/or group mentor	Recognizes a competent leader and/or group member, but is unable to identify the skills necessary to function as one	Able to identify the leadership and membership skills necessary to function as a member of a team in a school, family, or community setting and the causes of conflict within these settings	Able to describe and demonstrate the leadership and membership skills necessary to function as a member of a team in a school, family, or community setting and to use strategies to prevent or solve conflict within these settings	Consistently acts as a leader and as a productive group member in a variety of school, family, or community setting and incorporates conflict prevention or resolution skills into daily experiences
Civic	Unable to identify a public policy issue in our democracy	Able to identify a public policy issue in our democracy	Able to identify and describe a public policy issue in our democracy	Able to identify and evaluate a public policy issue in our democracy and explain the importance of active, informed, attentive citizen participation in addressing that issue	Actively participates in solving a civic problem and articulates the impact of his/her actions on public policy and constitutional democracy

Appendix G-1: Article Published at 2017 ASEE Conference

Embedding Fluid Power into Fluid Mechanics and Thermodynamics Courses through Problem-Based Learning and Entrepreneurially Minded Learning Modules

Dr. Liping Liu, Lawrence Technological University

Liping Liu is an assistant professor in the A. Leon Linton Department of Mechanical Engineering at Lawrence Technological University. She earned her Ph.D. degree in Mechanical Engineering from the University of Illinois in 2011. Her research focuses on thermal sciences and energy systems, with special interest in addressing transport phenomena in energy processes. She is a member of ASEE, ME, ASHRAE, and SAE International.

Dr. James A. Mynderse, Lawrence Technological University

James A. Mynderse, PhD is an Assistant Professor in the A. Leon Linton Department of Mechanical Engineering at Lawrence Technological University. His research interests include mechatronics, dynamic systems, and control with applications to piezoelectric actuators, hysteresis, and perception. He serves as the faculty advisor for the LTU Baja SAE team.

Dr. Robert W Fletcher, Lawrence Technological University

Robert Fletcher joined the faculty of the Mechanical Engineering Department at Lawrence Technological University in the summer of 2003, after two decades of various industry engineering positions in research, and product development.

Dr. Fletcher earned his Bachelor of Science Degree in Chemical Engineering from the University of Washington, in Seattle, and the Master of Science and Ph.D. degrees in Chemical Engineering, both from the University of Michigan.

He teaches a number of alternative energy courses at Lawrence Tech. Dr. Fletcher and his student research team is focusing on energy usage and efficiencies of several traditional and alternative energy systems.

Dr. Andrew L Gerhart, Lawrence Technological University

Andrew Gerhart, Ph.D. is a Professor of Mechanical Engineering at Lawrence Technological University. He is actively involved in ASEE and the American Society of Mechanical Engineers. He is a Fellow of the Engineering Society of Detroit. He serves as Faculty Advisor for the American Institute of Aeronautics and Astronautics Student Chapter at LTU, chair of the First Year Engineering Experience committee, chair for the LTU KEEN Course Modification Team, supervisor of the LTU Thermo-Fluids Laboratory, coordinator of the Certificate/Minor in Aeronautical Engineering, and faculty advisor of the LTU SAE Aero Design Team. Dr. Gerhart conducts workshops on active, collaborative, and problem-based learning, entrepreneurial mindset education, creative problem solving, and innovation. He is an author of a fluid mechanics textbook.

Embedding Fluid Power into Fluid Mechanics and Thermodynamics Courses through Problem-Based Learning and Entrepreneurially Minded Learning Modules

Abstract

This paper presents problem-based learning and entrepreneurially minded learning modules focused on fluid power applications in undergraduate Fluid Mechanics and Thermodynamics courses. This effort focuses on creating awareness and engaging students in the area of fluid power, and challenging them to apply the concepts and theories in class to analyze and design real-world fluid power systems. Therefore, the course modules target both technical and entrepreneurial mindset objectives. Assessment methods and results are detailed and discussed in the paper. Preliminary results indicate positive student learning in the area of fluid power and student practice of entrepreneurial skills.

Introduction

At Lawrence Technological University (Lawrence Tech), faculty are engaged in a multiyear process to incorporate active and collaborative learning (ACL), problem-based learning (PBL), and entrepreneurially minded learning (EML) into the engineering curriculum ^[1, 2, 3]. Active learning requires students to actively discuss issues or work problems in the classroom, rather than listening passively to a lecture. If students informally assist one another in this process, the technique is deemed collaborative learning ^[4]. A related approach, problem-based learning, introduces engaging real-world problems for students to solve, usually as part of a group ^[5]. A new twist on problem-based learning is the inclusion of student skills associated with an entrepreneurial mindset, such as integrating information from many sources to gain insight, conveying engineering solutions in economic terms, and identifying unexpected opportunities. The resulting entrepreneurially minded learning activities emphasize “discovery, opportunity identification, and value creation with attention given to effectual thinking over causal (predictive) thinking” ^[3]. At Lawrence Tech approximately 75% of the engineering curriculum, including mathematics and general education, is being modified to include ACL, PBL, and EML. These courses span the curriculum and range from multidisciplinary Introduction to Engineering ^[6, 7] to junior level technical courses ^[8, 9] to graduate level mechatronic design ^[10, 11].

As a member school in the Kern Entrepreneurial Engineering Network (KEEN), Lawrence Tech defines the entrepreneurial mindset in terms of the KEEN framework. The KEEN framework begins with the “three Cs”: Curiosity, Connections, and Creating Value ^[12]. Each of the three Cs is supported by example student behaviors. For instance, Curiosity is demonstrated by “explore a contrarian view of accepted solutions” and Creating Value is demonstrated by “identify unexpected opportunities to create extraordinary value”. The framework continues from the three Cs to Engineering Thought and Action, Collaboration, Communication, and Character. As with the three Cs, each concept is supported by example student behaviors. As noted by reference ^[3], “many of the example behaviors and complementary skills are well-represented in common

student-centered learning modules”. Therefore, modifications to enhance EML should focus on a subset of the example student behaviors that are less prevalent in PBLs.

In the undergraduate Mechanical Engineering curriculum, pneumatics and hydraulics (i.e., fluid power) often receive little to no coverage. In collaboration with the National Fluid Power Association (NFPA), Lawrence Tech faculty seek to improve undergraduate Mechanical Engineering education in the area of fluid power by leveraging effective ACL, PBL, and EML strategies. This work targets both student awareness of fluid power applications and technical skills related to pneumatics and hydraulics. Two core undergraduate mechanical engineering courses were modified to enhance fluid power content: Thermodynamics and Fluid Mechanics. Based on existing course content, Thermodynamics modifications focused on pneumatics while Fluid Mechanics modifications focused on hydraulics.

Starting in Fall 2016, the authors developed the fluid-power based modules and piloted them in two sections of Fluid Mechanics and two sections of Thermodynamics classes. Modules include a mix of low-effort in-class ACL activities, in-class demonstrations, individual homework assignments, and larger-scale PBL design projects. Preliminary direct and indirect assessment was performed after Fall 2016. Direct assessment via rubrics, to be reported in future work, will be used to assess students’ technical skills as demonstrated in design reports and oral presentations. Indirect assessment via student surveys was used to assess students’ awareness of and attitudes towards the fluid power industry, as well as growth in the entrepreneurial mindset^[9]. Based on assessment results, the piloted modules will be improved and implemented again in Spring 2017.

This work is organized as follows. First, the course modules implemented in Thermodynamics and Fluid Mechanics are described. Next, the direct and indirect assessment tools are introduced. Then the assessment results are presented and discussed. Finally, the work is concluded.

Description of the Course Modules

Activities in Thermodynamics

The focus for the new thermodynamics modules was to introduce students pneumatics. The thermodynamics course implementing the pneumatics module is typically taken in the junior year, predominantly by mechanical engineering students. However, some civil and architectural engineering students also are enrolled. This course is often the first truly analytical thermodynamics engineering course these students take with the extensive introduction and rigorous development of the abstract concepts of enthalpy and entropy. As a result, there are many new concepts presented to the student in this course. The majority of these students have not had industry experience and typically have not seen advance industrial automation or manufacturing technology that employs pneumatic systems.

With the recognition that many of these junior-year engineering student may be unaware of the wide use of pneumatic systems in manufacturing and are often ignorant of pneumatic technology, there were three goals proposed for the pneumatic modules in this course. First, students are introduced to the basics of pneumatic technology, pneumatic terminology, and

pneumatic concepts. Second, students are introduced to, and gain understanding of how pneumatics can be utilized and employed in industry and the basic components of pneumatic systems. Lastly, to address one of the NFPA goals for the funding grant, we want students to realize that there are indeed worthwhile engineering employment opportunities available to them in the pneumatics industry, and that these jobs can provide intellectually satisfying, and financially beneficial life-long employment opportunities.

There is always a challenge in adding more instructional materials to a course already “full” of content. To navigate through the added content the first two goals were addressed outside of class using online resources such as YouTube videos. For the last one students were directed to the NFPA website and reviewing the related employment information it contains. To accomplish these three goals, an assignment was issued to students that comprised the following components.

1. Watch the following three videos. Then answer the questions after each.
“Introduction to pneumatics” <https://www.youtube.com/watch?v=fM11hGJnqtQ>
 - a. Describe the basic operations you see in this video that are powered by pneumatic systems, or compressed air.
 - b. List the advantages to pneumatic systems given in this video.“Pneumatic Desktop capping machine with printing function for semi-auto shampoo production line” <https://www.youtube.com/watch?v=0zIINr3Vqj4>
 - c. You may need to watch this video a few times to see what is happening. Describe in detail what is taking place. Why is this operation beneficial?“A car that runs on air” <https://www.youtube.com/watch?v=uRpxhlX4Ga0>
 - d. The AirPod car is a vehicle powered by pneumatics (compressed air). Describe the history of using compressed air to provide power to move a vehicle.
 - e. What are the advantages to using a compressed air vehicle? Do you think it is practical? Why or why not?
2. Describe the basic components that would be needed in producing, storing and delivering enough high-pressures air to power machines, production lines, or even vehicles.
3. Go online to find references that can supplement and justify your answers. List and describe these references.
4. In chapter 3 of our Thermodynamics textbook we are learning about the nature of gases and the issues they face when compressed to high pressures. Review all of sections 3.11 and 3.12.
 - a. Describe the issues that are presented in these sections relating to compressed gases.
 - b. How would a thorough understanding of these topics be beneficial in pneumatics engineering applications and systems? Why? Elaborate upon your answer in detail.
5. There is a professional organization devoted to assisting and supporting engineers and manufacturing system designers in using fluid power. This organization is the National Fluid Power Association (NFPA). Their website is located at: <http://www.nfpa.com/>
 - a. Go to their website and review the various sections of their website. Describe what the NFPA sees as their mission.

- b. Under the “What is Fluid Power?”, they discuss several topics. Briefly describe these various topics.
- c. How they define pneumatics?
- d. They also give an example of how “a fluid pressure of 1,000 psi can push with 3140 lbs. of force. A pneumatic cylinder using 100 psi air would need a bore of almost 6½ in. (33 sq. in.) to develop the same force.” How is this so?
- e. Go to the “Education & Careers” section on the website. Under the “Employment” section review the companies listed where career opportunities exist. Pick three companies and describe how they may use pneumatics.

A second analytical computational assignment is being developed to help expand a student's knowledge of pressurized air and transitioning from ideal gas operational ranges to non-ideal gas pressure ranges and how those two ranges can impact pneumatic performance.

Activity in Fluid Mechanics

Fluid Mechanics is a junior-level course and two sections were taught in Fall 2016. During the final four weeks of the course, students were tasked to work in a self-selected team of three (with some teams of two) to design a fountain with hydraulically controlled nozzles. Each team was required to submit one technical report describing their detailed design. The project assignment (i.e., PBL/EML) is given below:

Fountain from Youth (a.k.a. Bellagio’s Little Cousin)

Three and half years ago, your rich uncle, Mortimer, purchased a large tract of land in the Upper Peninsula of Michigan. He did not become wealthy by purchasing worthless things, yet the land he bought has no valuable minerals, nor any profit from lumber. Instead, it has a magnificent wilderness resort lodge, which had been abandoned years ago and had fallen into a dilapidated state. The lodge is known as the Overlook Hotel. (No, not *that* Overlook Hotel from *The Shining*; that place makes people go crazy and is located in the mountains of Colorado.) After Uncle Mortimer restored the Overlook, his guests come to enjoy forest hiking, mountain biking, and a variety of other outdoor pursuits. Some just come to enjoy the peace and quiet at the hotel. Since the Overlook is located on a rocky hillside 300 vertical feet above the lake (which is what the hotel “overlooks”) and 2200 ground feet from the lake’s edge, he installed a chair lift for downhill skiing to draw customers during the brutally cold winter months. He has also installed a surface called “Snowflex” so that skiers can enjoy the slopes in both summer and winter. Yet with all that, there is one more element that Uncle Mort feels would really enhance his hotel: a mesmerizing fountain display. He has seen the fabulous Bellagio Fountains, and enjoys the interesting fountain in the McNamara Terminal of the Detroit Metropolitan Airport. He wants something that will be appropriate for his wilderness resort.

After learning of your vast new knowledge of fluid mechanics, he has asked you to design a fountain. As a member of the National Fluid Power Association, he

requires that one or more of the nozzles is controlled by a hydraulic system which will allow the nozzle(s) to move the water jet(s) in some sort of pattern. The water jet(s) from the movable nozzle(s) must be high enough pressure to allow for a sufficient water height. He wants this fountain to be an attraction for his customers. You will need to consider a water delivery system, filter(s), a piping system, hydraulic system, and other components for this fountain.

Preliminary Reply Investigation: some (not all) considerations during the first week:

- What major components are needed for a fountain and a hydraulically controlled device?
- What should be the overall footprint size of the fountain?
- What intriguing display features should the fountain exhibit, and how many nozzles does that require?
- What items have a significant cost for operation?

Some considerations:

- Ensure that the fountain has sufficient water flow and pressure.
- Be careful with pipe selection (sizing) and material, ensuring that the water is fairly equally distributed throughout the area based on the display options. Carefully consider the layout of the water system so as not to overcomplicate the problem.
- Be cautious that the components and design are not too costly. You should keep track of approximate expenses for components, and keep notes of how you kept costs down. Uncle Mort will want to know. You do not need to consider installation costs, unless your design plan is especially unique. (Consult your customer to determine if installation costs are required for your plan.)
- Include operational expenses for Uncle Mortimer. In other words, choose your water delivery system wisely. What will it cost per year to run the water operation?
- You are designing the fluid system and hydraulic system only, not the solid structure of the pool, pipe/pump support, etc. On the other hand, you must consider forces from the nozzles (as per the hydraulic system requirements). You will also have to consider placement of the various components and, of course, sizes.
- Be careful with all fluid components sizing (pipes, pumps, etc.). Do not drastically oversize or undersize your pump(s).
- Valves....
- The hillside continues above the lodge another 400 vertical feet to the summit in 600 ground feet.

In the process of completing this PBL/EML, students must gather information from their customer, Uncle Mort, role-played by the course instructor. The students will not only solve the technical problem, but must communicate their solution in economic terms. Finally the students should be looking for unexpected opportunities that will enhance the value for their customer. A

few of these opportunities are “hidden” within the problem statement. For example, the extended hillside above the lodge can be used for a water tank and additional water pressure, decreasing pump size at the lake. In addition, because of the low power needed for hydraulic control, water can be used for the hydraulic fluid instead of more expensive (and complex) hydraulic fluid. More information on unexpected opportunities and their use in EML modules can be found in reference^[3].

Assessment Method

It must be specifically noted here that for the thermodynamics module, the authors have not incorporated any examples of student responses to the various questions asked in the first thermodynamics pneumatics assignment because none of the eighteen students in this class agreed to allow their answers from their work to be shown as evidence in this paper.

The final versions (as was done for the first version of the first assignment) of the thermodynamics modules will be evaluated using a fully-developed answer sheet for comparing the student's responses to the desired and expected answers to the assignment, as is typically employed in standard engineering courses. The second assignment (still being developed) will contain a higher analytic computational emphasis and be specifically based on pre-determined educational knowledge outcomes and computational understanding that is considered fundamental for basic application skills in the pneumatics industry. Assessment of all questions asked in this second assignment will also employ a grading rubric. This grading rubric will also be specifically based on the pre-determined educational knowledge outcomes and computational understanding that were considered fundamental for basic application skills in the pneumatics industry. Once this grading rubric is developed then it will be used by the individual reviewing (grading) the second assignment to compare the student's responses to the rubric to assure answer compliance. Lastly, one informal class discussion (approximately fifteen minutes long) with the students about these assignments and information gained by the students from these assignments will be held with each class. Such direct, but “soft”, feedback will be noted by the course instructor, and may also be used to potentially sharpen the focus of future assignments, and to possibly help clarify for students any aspects of the materials covered.

In order to evaluate the students' outcome of the PBL/EML activity in Fluid Mechanics, a survey was distributed to students to acquire their perceptions and experience about their design process. The students were asked to answer the question “This project improved my technical skills in:”

- i. Identifying the components and functions of a pipe system.
- ii. Identifying the components and functions of a hydraulic system.
- iii. Making reasonable simplifying assumptions.
- iv. Analyzing the function of various flow components (pumps, valves, etc.)
- v. Identifying and determining major and minor losses in a flow system.
- vi. Predicting pressure and pipe size for series piping systems.
- vii. Determining the required pumping power according to flow requirements.
- viii. Choosing an actual pump that meets the flow requirements.
- ix. Designing a real-world fluid mechanics system.
- x. Reporting the solution to a customer.

Answers were provided as scales from 1 to 5:

1. Strongly disagree
2. Disagree
3. No opinion
4. Agree
5. Strongly agree

Besides evaluating the students on technical skills, they were also assessed for entrepreneurial mindset learning. The students were given the following statements and were asked to provide their perception in the same scales 1 to 5:

- a. My project design satisfied the customer's needs and goals.
- b. I consider the results of my project successful.
- c. I found my work on the project to be satisfying.
- d. The real-world application of the project motivated me to do my best work.
- e. The open-ended nature of the project motivated me to do my best work.

The students were asked to answer questions in regards to example behaviors of the entrepreneurial mindset - directly addressing the student outcomes from Kern Entrepreneurial Engineering Network (KEEN) - in the format of "During the course of this project, to what extent did you:"

- f. Explore a contrarian view of accepted (i.e., typical) solutions.
- g. Identify an unexpected opportunity for your design.
- h. Create extraordinary value for a customer or stakeholder.
- i. Integrate information from many sources to gain insight.
- j. Assess and manage risk.
- k. Persist through failure.
- l. Apply creative thinking to ambiguous problems.
- m. Apply systems thinking to complex problems.
- n. Evaluate economic drivers.
- o. Examine a customer's or stakeholder's needs.
- p. Understand the motivations and perspectives of others.
- q. Convey engineering solutions in economic terms.
- r. Substantiate claims with data and facts.

The answers were provided in 5 scales:

1. None at all
2. Slightly
3. On some occasions
4. Many times
5. Throughout most of the project

Following the questions above, the students were also asked about their team dynamics:

- s. To what extent did you work as a team?

Answers are provided in 5 scales:

1. Almost never
2. Rarely
3. Sometimes
4. Often
5. Almost always

The students were also welcomed to provide commentary statements about their problem-based learning experience. They were asked what they liked or appreciated about the project, what should be changed, and any other additional comments/observations.

Results and Discussion

Thermodynamics Course

The initial review of the first assignment module for the thermodynamics course was quite positive. Eighteen students were in this class, with all students completing the assignment. As was noted above, however, the authors have not incorporated any examples of student responses to the various questions asked in the first thermodynamics pneumatics assignment because none of the eighteen students in this class agreed to allow their answers from their work to be shown as evidence in this paper. The authors can state that, based on the answers provided by the students, it was clear that the overall subject of pneumatics was new to the majority of students in the class. They may, however, have known about air-driven tools, and compressor air systems, but they previously did not associate those systems with pneumatics. As a result, the students were quickly able to relate to technology that they did know about with concepts that they did not understand were part of pneumatics. The authors will work to use the knowledge of air-driven tools as a possible better introduction to the broader field of pneumatics.

An area that was disappointing on this initial assignment was the brevity of answers provided by students, and the lack of expansion and development of their answers. This first assignment needs modification so as to have wording and questions that require more discussion and detail. This will assure more comprehensive answers and responses from the students to the prompting questions in the assignment.

In spite of the moderate shortcomings observed in the work of students for this assignment, there were also real benefits. It was learned during a short class discussion after the assignment was issued that the consensus of the students gained a great deal of introductory knowledge regarding pneumatics. Such short discussions will be held in future classes. Some students expressed surprise that there was an entire industry built around pneumatics, and there were viable career opportunities in that field. In these regards, the initial introductory module in pneumatics is viewed as a success.

Fluid Mechanics Course

The survey results assessing the students' perception about technical learning are presented in Table 1. The results are from a total of 12 students. The average number for all the ten questions are above 3.0, indicating that the students perceived that the problem-based learning exercise

helped them improve their learning on the technical content. The results are also illustrated in Figure 1. The two items with highest performance are an average of 4.33 in item “i” – Identifying the components and functions of a pipe system and an average of 4.36 in item “iv” - Analyzing the function of various flow components (pumps, valves, etc.). The results also indicate that through this activity the students practiced synthesizing information from different topics learned during the course and applying it to solve a real-world fluid mechanics system (an average of 3.83 in question “ix”).

Table 1. Survey results assessing technical skills in Fluid Mechanics Course

Question	Mean	Standard Deviation
i. Identifying the components and functions of a pipe system.	4.33	0.49
ii. Identifying the components and functions of a hydraulic system.	3.42	0.90
iii. Making reasonable simplifying assumptions.	3.92	0.51
iv. Analyzing the function of various flow components (pumps, valves, etc.)	4.36	0.50
v. Identifying and determining major and minor losses in a flow system.	3.83	0.94
vi. Predicting pressure and pipe size for series piping systems.	4.00	0.95
vii. Determining the required pumping power according to flow requirements.	3.75	0.45
viii. Choosing an actual pump that meets the flow requirements.	3.83	0.58
ix. Designing a real-world fluid mechanics system.	3.83	0.72
x. Reporting the solution to a customer.	3.67	0.65

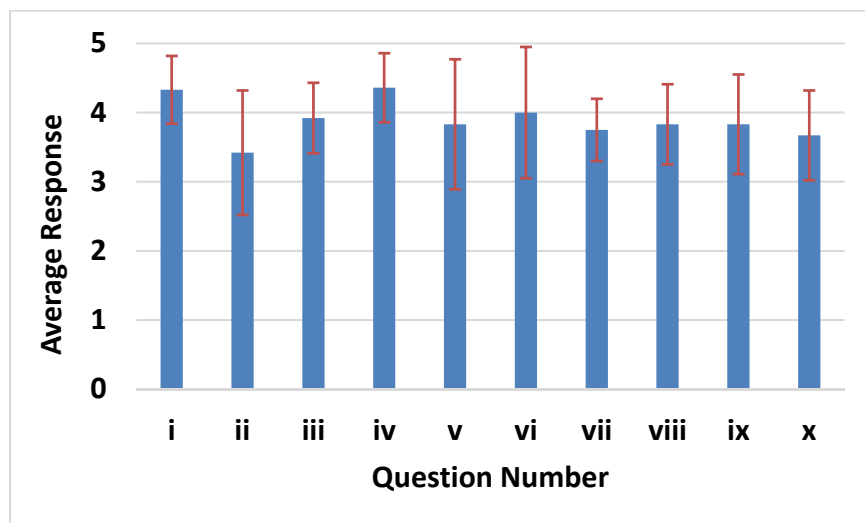

Figure 1. Survey results assessing technical skills in Fluid Mechanics Course

Students' answer to item "ii" - Identifying the components and functions of a hydraulic system - shows the lowest performance among all the ten questions. However, it should be noted that elements of "fluid power" are usually not specifically covered in detail in the classroom of a standard Fluid Mechanics course. The students' score of 3.42 implies that the students were at least exposed to the concepts and application of hydraulic systems during this design exercise. The students also admitted that this project forced them to do a lot of research and reading in this area.

Table 2. Survey results for entrepreneurial mindset in the Fluid Mechanics Course

Question	Mean	Standard Deviation
a. My project design satisfied the customer's needs and goals.	3.67	0.78
b. I consider the results of my project successful.	3.67	0.89
c. I found my work on the project to be satisfying.	3.50	0.90
d. The real-world application of the project motivated me to do my best work.	3.67	0.78
e. The open-ended nature of the project motivated me to do my best work.	3.75	0.75
f. Explore a contrarian view of accepted (i.e., typical) solutions.	3.75	0.97
g. Identify an unexpected opportunity for your design.	3.17	0.72
h. Create extraordinary value for a customer or stakeholder.	3.00	0.74
i. Integrate information from many sources to gain insight.	3.83	0.83
j. Assess and manage risk.	3.17	0.72
k. Persist through failure.	3.50	0.90
l. Apply creative thinking to ambiguous problems.	3.50	0.52
m. Apply systems thinking to complex problems.	3.25	0.75
n. Evaluate economic drivers.	3.42	0.67
o. Examine a customer's or stakeholder's needs.	3.58	0.79
p. Understand the motivations and perspectives of others.	3.50	0.80
q. Convey engineering solutions in economic terms.	3.75	0.87
r. Substantiate claims with data and facts.	3.83	0.94
s. To what extent did you work as a team?	3.83	1.19

The data shown in Table 2 are the student feedback about entrepreneurial mindset learning to the PBL/EML activity implemented in Fluid Mechanics. The results are also presented as a bar graph in Figure 2. As shown in the Figure, the design project allowed students to gain various practice of entrepreneurial skills. The activity particularly addressed the student outcomes of "integrate information from many sources to gain insight" and "substantiate claims with data and facts" (average feedback of 3.83 to survey questions "i" and "r"). It is also clear that this highly collaborative activity facilitates team work and forces students to work together (average feedback of 3.83 to survey question "s"). The students did not feel that they created

extraordinary value (item “h”). There is likely two explanations for this. First “extraordinary” is a strong term. This is the first experience students have had design an entire fountain; they certainly would feel they could design a better one with more experience and/or with more expert guidance. Second, the students feel time pressure at the end of the semester with multiple deadlines looming from all of their coursework. The students likely felt that they could have produced a better fountain if they could have devoted full-time to its development.

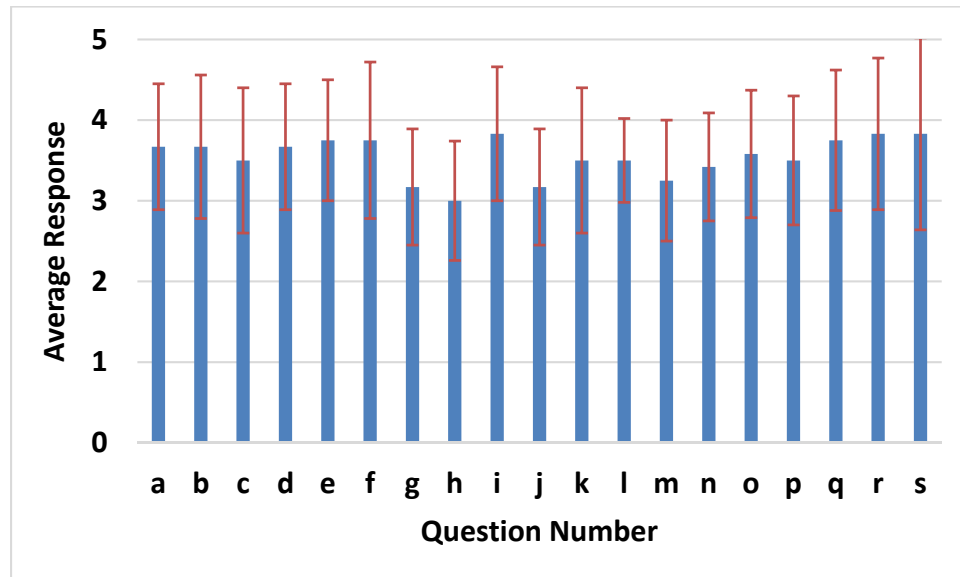

Figure 2. Survey results for entrepreneurial mindset in the Fluid Mechanics Course

On the survey many students wrote comments about their learning experience through this PBL exercise. Most of them mentioned that they liked applying what they are learning from class to real-world problem solving, and they appreciated the open-ended nature of the problems, which are directly addressing survey questions “d” and “e”. Several student comments are listed as examples:

- “It was realistic and I could apply what we're learning directly to the problem. It relied on using a lot of references from the book directly instead of relying on outside sources... for what I was struggling to work with. My partner was very good at helping me understand.”
- “This project made us think critically about what will happen to water flow under certain conditions. For example, pressure loss, flow rates through different size pipes.”
- “It is not limited in textbook so that the question is more open and combined with real life applications.”
- “If a hydraulic system is required, we should spend some class time discussing how one works and how to find the losses within one of those.”
- “We were able to be creative. The project was open to how we wanted to design the system.”
- “I liked how it incorporated many aspects of the fluid mechanics curriculum. It used many chapters to come up with an end result that could be related to the real world.”

The instructor has some concern that the students are not comfortable implementing the hydraulic system to the fountain nozzles. While an example hydraulics problem is solved in class, it is very early in the academic term, nearly two months before the project is assigned. In the future, the instructor will remind the students of the example, and perhaps even briefly describe the components necessary in a hydraulic power system.

The work is ongoing to improve and complete the modules and assessment methods. More assessment will be performed in future semesters. The authors will collect more comparison data and a pre-survey will also be developed to get student feedback before and after the activities.

Conclusions

Active learning and problem-based learning modules were developed and implemented in Thermodynamics and Fluid Mechanics courses to engage students in the area of fluid power. These collaborative learning activities allow students to work in teams, integrate information from many sources, and apply creative thinking to ambiguous problems. In addition, the students gained insight into the field of fluid power and employment opportunities, material which was previously neglected in the courses. Indirect assessment results indicate that students perceive extensive practice in various aspects of entrepreneurial skills.

Acknowledgement

The authors gratefully acknowledge the National Fluid Power Association (NFPA) for sponsoring the presented work.

References

- [1] D. Carpenter, K. Hayes, C. Ward and A. L. Gerhart, "Assessment and Evaluation of a Comprehensive Course Modification Plan," *The Journal of Engineering Entrepreneurship*, vol. 2, no. 2, 2011.
- [2] A. L. Gerhart and D. D. Carpenter, "Campus-wide Course Modification Program to Implement Active & Collaborative Learning and Problem-based Learning to Address the Entrepreneurial Mindset," in *Proc. 2013 ASEE Annual Conference and Exposition*, Atlanta, GA, 2013.
- [3] A. L. Gerhart and D. E. Melton, "Entrepreneurially Minded Learning: Incorporating Stakeholders, Discovery, Opportunity Identification, and Value Creation into Problem-Based Learning Modules with Examples and Assessment Specific to Fluid Mechanics," in *Proc. 2016 ASEE Annual Conference & Exposition*, 2016.
- [4] K. A. Smith, S. D. Sheppard, D. W. Johnson and R. T. Johnson, "Pedagogies of Engagement: Classroom-Based Practices," *Journal of Engineering Education*, vol. 94, no. 1, pp. 87-101, 2005.
- [5] M. Prince, "Does Active Learning Work? A Review of the Research," *Journal of Engineering Education*, vol. 93, no. 3, pp. 223-331, 2004.
- [6] A. L. Gerhart and R. W. Fletcher, "Project-Based Learning and Design Experiences in Introduction to Engineering Courses: Assessing an Incremental Introduction of Engineering Skills," in *Proc. 2011 ASEE Annual Conference & Exposition*, 2011.

- [7] A. L. Gerhart, D. D. Carpenter, R. W. Fletcher and E. G. Meyer, "Combining Discipline-specific Introduction to Engineering Courses into a Single Multidiscipline Course to Foster the Entrepreneurial Mindset with Entrepreneurially Minded Learning," in *Proc. 2014 ASEE Annual Conference & Exposition*, 2014.
- [8] J. A. Mynderse, A. L. Gerhart, L. Liu and S. Arslan, "Multi-course Problem-based Learning Module Spanning Across the Junior and Senior Mechanical Engineering Curriculum: Mechatronics, Fluid Mechanic, and Heat Transfer," in *2015 ASEE Annual Conference & Exposition*, Seattle, 2015.
- [9] L. Liu, J. A. Mynderse, A. L. Gerhart and S. Arslan, "Fostering the Entrepreneurial Mindset in the Junior and Senior Mechanical Engineering Curriculum with a Multi-Course Problem-based Learning Experience," in *Proc. 45th ASEE/IEEE Frontiers in Education Conference*, 2015.
- [10] J. A. Mynderse and J. N. Shelton, "Implementing Problem-Based Learning in a Senior/Graduate Mechatronics Course," in *Proc. 2014 ASEE Annual Conference and Exposition*, Indianapolis, 2014.
- [11] J. A. Mynderse and J. Shelton, "Assessment of an Improved Problem-Based Learning Implementation in a Senior/Graduate Mechatronic Design Course," in *Proc. 2015 ASEE Annual Conference and Exposition*, Seattle, 2015.
- [12] Kern Entrepreneurial Engineering Network, "Entrepreneurial Mindset 101," [Online]. Available: <http://engineeringunleashed.com/keen/em101/>.

Appendix G-2: Article Published at 2017 FIE Conference

Embedding Problem-Based Learning and Entrepreneurially Minded Learning into Fluid Mechanics and Thermodynamics Courses through Fluid Power Based Modules

Liping Liu, James Mynderse, Robert Fletcher, and Andrew Gerhart

A. Leon Linton Department of Mechanical Engineering
Lawrence Technological University
Southfield, MI, United States

lliu1@ltu.edu; jmynderse@ltu.edu; rfletcher@ltu.edu; agerhart@ltu.edu

Abstract—Problem-based learning and entrepreneurially minded learning modules have been developed to include fluid power concepts into undergraduate Mechanical Engineering core courses Thermodynamics and Fluid Mechanics. Modules in Thermodynamics focus on pneumatics and modules in Fluid Mechanics focus on hydraulics. The purpose of this work is to assess the created modules for student awareness of fluid power, knowledge of fluid power concepts, and growth in the entrepreneurial mindset. Both direct and indirect methods were used for assessment. Assessment results indicate that students applied fluid power concepts that are traditionally not covered in these courses. Student surveys also indicate that students demonstrated sample behaviors associated with the entrepreneurial mindset, as defined by the Kern Entrepreneurial Engineering Network framework.

Keywords—*Fluid Mechanics; Thermodynamics; Fluid Power; Problem-Based Learning; Entrepreneurially Minded Learning*

I. INTRODUCTION

Lawrence Technological University (Lawrence Tech) is engaged in a multi-year process to incorporate active and collaborative learning (ACL), problem-based learning (PBL), and entrepreneurially minded learning (EML) into the engineering curriculum [1, 2, 3]. This effort was funded by an institutional grant from the Kern Family Foundation, but has become entrenched within the College of Engineering culture as a focus on novel pedagogical tools. Approximately 75% of the engineering curriculum, including mathematics and general education, has been modified to include ACL and PBL. EML course modifications are in-progress. Courses with ACL or PBL components span the curriculum and range from multidisciplinary Introduction to Engineering [4, 5] to junior level technical courses [6, 7] to graduate level mechatronic design [8, 9].

Faculty cohorts from across the university were trained in ACL, PBL, and EML techniques through summer workshops. Active learning course modifications require students to actively discuss issues or work problems in the classroom,

rather than listening passively to a traditional lecture. If students informally assist one another (with encouragement from the instructor) in this process, the technique is deemed to be collaborative learning [10]. Problem-based learning, a subset of active learning techniques, introduces engaging real-world problems for students to solve, usually as part of a group [11]. These PBL activities may span several weeks or longer and may include both in-class and out-of-class time for student teams.

A new approach to problem-based learning is the inclusion of student skills associated with an entrepreneurial mindset, such as integrating information from many sources to gain insight and identifying unexpected opportunities. As a member school in the Kern Entrepreneurial Engineering Network (KEEN), Lawrence Tech defines the entrepreneurial mindset in terms of the KEEN framework. The KEEN framework begins with the “three Cs”: Curiosity, Connections, and Creating Value [12]. Each of the three Cs is supported by example student behaviors. For instance, Curiosity is demonstrated by “explore a contrarian view of accepted solutions” and Creating Value is demonstrated by “identify unexpected opportunities to create extraordinary value”. The framework continues from the three Cs to Engineering Thought and Action, Collaboration, Communication, and Character. As with the three Cs, each concept is supported by example student behaviors. The resulting entrepreneurially minded learning activities emphasize “discovery, opportunity identification, and value creation with attention given to effectual thinking over causal (predictive) thinking” [3]. While similar in nature to skills valued by entrepreneurs, the entrepreneurial mindset does not necessitate the creation of new ventures. Rather, it is the application of the “three Cs” to engineering practice.

In collaboration with the National Fluid Power Association (NFPA), faculty at Lawrence Tech are developing and implementing fluid power based modules for two BSME core courses: Fluid Mechanics and Thermodynamics. These new modules utilize PBL and EML techniques to address three aims. First, the modules engage students in the study of fluid power

as an application of fluid mechanics and thermodynamics. Next, the modules help to create awareness of fluid power applications and careers in BSME students. Finally, the modules foster the entrepreneurial mindset through the application of traditional classroom studies to complex, real-world problems with a variety of stakeholders and economic constraints.

In Fall 2016, the authors developed and piloted the fluid power based modules in undergraduate Fluid Mechanics and Thermodynamics classes (two sections of each). The modules include student activities and assignments, team design projects, and in-class demonstrations, where appropriate for the course and material. Based on initial assessment results, the modules were improved and implemented again in Spring 2017. Modules for Fluid Mechanics focus on hydraulics applications and modules for Thermodynamics focus on pneumatics applications. Both direct and indirect assessment tools were developed. Direct assessment was used primarily to gauge student learning of traditional class material. Student surveys provided their perception of the learning experience and demonstration of entrepreneurial mindset example behaviors.

The remainder of this work is organized as follows. Section II introduces the course modules for Fluid Mechanics and Thermodynamics. Section III describes the assessment methods. Section IV discusses the results and Section V concludes the work.

II. DESCRIPTION OF COURSE MODULES

A. *Modules in Fluid Mechanics*

Fluid Mechanics is a course required for all Mechanical Engineering undergraduate students at Lawrence Tech. Four sections were offered in the past year: two in Fall 2016 and two in Spring 2017. The enrolled students are predominantly juniors. During the last four or five weeks of the course, students were assigned a team PBL/EML project to design a fountain with hydraulically controlled nozzles. The students were allowed to select their own teams of three members, and each team submitted one technical report describing their detailed design. The detailed description of the project assignment is provided below:

Fountain from Youth (a.k.a. Bellagio's Little Cousin)

Three and half years ago, your rich uncle, Mortimer, purchased a large tract of land in the Upper Peninsula of Michigan. He did not become wealthy by purchasing worthless things, yet the land he bought has no valuable minerals, nor any profit from lumber. Instead, it has a magnificent wilderness resort lodge, which had been abandoned years ago and had fallen into a dilapidated state. The lodge is known as the Overlook Hotel. (No, not that Overlook Hotel from *The Shining*; that place makes people go crazy and is located in the mountains of Colorado.) After Uncle Mortimer restored the Overlook, his guests come to enjoy forest hiking, mountain biking, and a variety of other outdoor pursuits. Some just come to enjoy the peace and quiet at the hotel. Since the Overlook is located on a rocky hillside 300 vertical feet above the lake (which is what the hotel "overlooks") and 2200 ground feet

from the lake's edge, he installed a chair lift for downhill skiing to draw customers during the brutally cold winter months. He has also installed a surface called "Snowflex" so that skiers can enjoy the slopes in both summer and winter. Yet with all that, there is one more element that Uncle Mort feels would really enhance his hotel: a mesmerizing fountain display. He has seen the fabulous Bellagio Fountains, and enjoys the interesting fountain in the McNamara Terminal of the Detroit Metropolitan Airport. He wants something that will be appropriate for his wilderness resort.

After learning of your vast new knowledge of fluid mechanics, he has asked you to design a fountain. As a member of the National Fluid Power Association, he requires that one or more of the nozzles is controlled by a hydraulic system which will allow the nozzle(s) to move the water jet(s) in some sort of pattern. The water jet(s) from the movable nozzle(s) must be high enough pressure to allow for a sufficient water height. He wants this fountain to be an attraction for his customers. You will need to consider a water delivery system, filter(s), a piping system, hydraulic system, and other components for this fountain. Your design must be cost effective in regards to value; Uncle Mort wants his customers to be satisfied and a fair return on his investment.

Preliminary Reply Investigation: some (not all) considerations during the first week:

- What major components are needed for a fountain and a hydraulically controlled device?
- Where will the fountain be located, what will be its overall footprint size, and when/how often will it be operational?
- What intriguing display features should the fountain exhibit, and how many nozzles does that require? How many of the nozzles are hydraulically controlled?
- What items have a significant cost for operation?

Some considerations:

- Ensure that the fountain has sufficient water flow and pressure.
- Be careful with pipe selection (sizing) and material, ensuring that the water is fairly equally distributed throughout the area based on the display options. Carefully consider the layout of the water system so as not to overcomplicate the problem.
- Be cautious that the components and design are not too costly. You should keep track of approximate expenses for components, and keep notes of how you kept costs down. Uncle Mort will want to know. You do not need to consider installation costs, unless your design plan is especially unique. (Consult your customer to determine if installation costs are required for your plan.)
- Include operational expenses for Uncle Mortimer. In other words, choose your water delivery system wisely. What will it cost per year to run the water operation?
- You are designing the fluid system and hydraulic system only, not the solid structure of the pool, pipe/pump support, etc. On the other hand, you must consider forces from the nozzles (as per the hydraulic system requirements). You will also have to consider placement of the various components and, of course, sizes.

- Be careful with all fluid components sizing (pipes, pumps, etc.). Do not drastically oversize or undersize your pump(s).
- Valves....
- The hillside continues above the lodge another 400 vertical feet to the summit in 600 ground feet.

While working on this PBL/EML project, the students needed to communicate frequently with their customer, Uncle Mort, role-played by the course instructor. The students needed to learn about the requirements from their customer, and understand his perspective. They not only had to come up with the technical design, but also had to communicate their solution in economic terms (for example, provide the estimated cost of building and/or operating the system).

B. Modules in Thermodynamics

Engineering students at Lawrence Tech typically take Thermodynamics in their junior year. Students are predominantly BSME students with some civil and architectural engineering students also enrolled. The first challenge is that the course contains extensive exposure to and development of abstract concepts such as enthalpy and entropy. The introduction of these new concepts, frequently at the same time, forces the students to work aggressively and rapidly to keep pace with the course materials. There is always a challenge in adding more instructional materials to a course already “full” of content. In addition, many of these students have not had industry experience, may not have worked in an area involving industrial automation or manufacturing technology, and so may not be familiar with pneumatic systems.

To address these three issues, the topic of pneumatics was broken into two educational modules. The first module introduces the student to the widespread use of pneumatic systems in manufacturing and the importance of pneumatic technology, pneumatic terminology, and pneumatic concepts. The second module, still under development, will focus more on computational aspects of pneumatics including transitioning from ideal gas operational ranges to non-ideal gas pressure ranges.

In the first module, students learn how pneumatics are utilized and deployed in industry, and what constitutes the basics of pneumatic systems. This first module is completed by students outside of class using online resources such as YouTube videos. Students also learn there are viable engineering employment opportunities available to them in the pneumatics industry by directing them to the NFPA website and the related employment information it contains. Examples of the first module content is given below:

1. Watch the following three videos. Then answer the questions after each.

“Introduction to pneumatics”
<https://youtu.be/fM11hGJnqtQ>

- a. Describe the basic operations you see in this video that are powered by pneumatic systems, or compressed air.

- b. List the advantages to pneumatic systems given in this video.

“Pneumatic Desktop capping machine with printing function for semi-auto shampoo production line”
<https://www.youtube.com/watch?v=0zIINr3Vqj4>

- c. You may need to watch this video a few times to see what is happening. Describe in detail what is taking place. Why is this operation beneficial?

“A car that runs on air”
<https://youtu.be/uRpxhIX4Ga0>

- d. The AirPod car is a vehicle powered by pneumatics (compressed air). Describe the history of using compressed air to provide power to move a vehicle.
- e. What are the advantages to using a compressed air vehicle? Do you think it is practical? Why or why not?

2. Describe the basic components that would be needed in producing, storing and delivering enough high-pressure air to power machines, production lines, or even vehicles.
3. Go online to find references that can supplement and justify your answers. List and describe these references.
4. In chapter 3 of our Thermodynamics textbook we are learning about the nature of gases and the issues they face when compressed to high pressures. Review all of sections 3.11 and 3.12.

- a. Describe the issues that are presented in these sections relating to compressed gases.
- b. How would a thorough understanding of these topics be beneficial in pneumatics engineering applications and systems? Why? Elaborate upon your answer in detail.

5. There is a professional organization devoted to assisting and supporting engineers and manufacturing system designers in using fluid power. This organization is the National Fluid Power Association (NFPA). Their website is located at:

<http://www.nfpa.com/>

- a. Go to their website and review the various sections of their website. Describe what the NFPA sees as their mission.
- b. Under the “What is Fluid Power?”, they discuss several topics. Briefly describe these various topics.
- c. How they define pneumatics?
- d. They also give an example of how “a fluid pressure of 1,000 psi can push with 3140 lbs. of force. A pneumatic cylinder using 100 psi air would need a bore of almost 6½ in. (33 sq. in.) to develop the same force.” How is this so?
- e. Go to the “Education & Careers” section on the website. Under the “Employment” section review the companies listed where career opportunities exist.

Pick three companies and describe how they may use pneumatics.

In the second module, students will focus on computational aspects of pneumatic systems. This module will help expand a student's knowledge of pressurized air and transitioning from ideal gas operational ranges to non-ideal gas pressure ranges and how those two ranges can impact pneumatic performance. An important outcome for students is also to know typical operation pressures of pneumatics systems and their relationship to ideal gas assumptions. Examples of this second module's content is given below:

1. Most industrial pneumatic systems operate using standard 100 psig compressed air (available in most industrial operations). Watch the following Youtube video to understand some basics of pneumatic air compressors:

“How to Choose and Use an Air Compressor”

<https://youtu.be/u6zddqNldFs>

2. Two engineers are discussing if typical 100 psig compressed air used in a pneumatic driven and controlled manufacturing operation can be considered an ideal gas and, therefore, allows them to use the ideal gas law. You can assist them by referencing the compressibility factor “Z”. Use the compressibility factor Z and the information from Figure A-1 (on page 1021 of our course textbook) to quantitatively and computationally justify if the 100 psig shop air can, or cannot, be considered an ideal gas. (Recall that for many applications values of “Z” within the range of 0.96 to 1.04 could easily allow the use of the ideal gas law with few problems and little error.)
3. A piston-cylinder system has the following configuration. A piston has an outer diameter of 5 cm, and slides freely within a cylinder with the same inner diameter. The cylinder is fully sealed and closed at one end and the other end is open, allowing for the movement of the piston. Initially the piston is located 1 meter from the closed end of the cylinder. Initially conditions of the air are:

$$T_1 = 26\text{ }^\circ\text{C}$$
$$P_1 = 1\text{ atmosphere}$$

- a) At these initial conditions it is reasonable to use the ideal gas law. The piston, however, is then very rapidly pressed into the cylinder. No air leaves the piston-cylinder assembly. The piston is pressed quickly into the cylinder (within a fraction of a second) and locked into place. The piston movement is so rapid that the air/system can initially be assumed to be adiabatic. At this new piston position, the air temperature within the cylinder correspondingly and momentarily rises to 550°C and the air pressure increases to 100 atmospheres. At the instant of the new piston position is it still reasonable to assume the air in the cylinder is an ideal gas? Quantitatively and computationally verify this using “Z” from Figure A-2.

- b) Compute the work that was rapidly applied to the piston to move it to the new position within the cylinder.
- c) The piston and cylinder are left at the new piston position remains locked into place, and left to sit for several hours such that the temperature of the gas and the cylinder are allowed to return to the initial temperature of 26°C, but the piston does not move from the new position. Determine the pressure of the air within the cylinder under these conditions.

The Fluid Mechanics and Thermodynamics modules presented above were developed in Fall 2016. Initial implementation and assessment were also carried out in the same semester, with valuable feedback collected from course instructors and students. The modules were then modified and improved based on the assessment results. Fluid Mechanics modules were implemented and assessed again in Spring 2017, while the Thermodynamics modules will be re-implemented in Summer and/or Fall 2017.

III. ASSESSMENT METHODS

A. Assessment in Fluid Mechanics

Upon completing the project, students were directly and indirectly assessed for technical skills. The indirect assessment was administered via student survey which attempts to gauge their perceptions and experience about their design process. The students were asked to answer the question “This project improved my technical skills in:”

- i. Identifying the components and functions of a pipe system.
- ii. Identifying the components and functions of a hydraulic system.
- iii. Making reasonable simplifying assumptions.
- iv. Analyzing the function of various flow components (pumps, valves, etc.)
- v. Identifying and determining major and minor losses in a flow system.
- vi. Predicting pressure and pipe size for series piping systems.
- vii. Determining the required pumping power according to flow requirements.
- viii. Choosing an actual pump that meets the flow requirements.
- ix. Designing a real-world fluid mechanics system.
- x. Reporting the solution to a customer.

Answers were provided as scales from 1 to 5:

1. Strongly disagree
2. Disagree
3. No opinion
4. Agree
5. Strongly agree

The direct assessment of technical learning was conducted using a problem-based learning rubric to evaluate the quality of the problem solutions. There are a total of nine rubric criteria:

- xi. Identification of problem
- xii. Data collection
- xiii. Representing data
- xiv. Verify and evaluate information
- xv. Draw conclusions and make appropriate applications
- xvi. Justify and support decisions, strategies, findings and solutions
- xvii. Communicate purpose and/or main idea for audience
- xviii. Organization
- xix. Supporting details and/or visuals

Each criterion was graded as five scales:

- 0. No demonstration
- 1. Attempted demonstration
- 2. Partial demonstration
- 3. Proficient demonstration
- 4. Sophisticated demonstration

Besides the evaluation of students' technical learning, they were also assessed for entrepreneurial mindset learning. The team members were given the following statements and were asked to provide their perception in scales 1 to 5 where 1 corresponds to "strongly disagree" and 5 corresponds to "strongly agree":

- a. My project design satisfied the customer's needs and goals.
- b. I consider the results of my project successful.
- c. I found my work on the project to be satisfying.
- d. The real-world application of the project motivated me to do my best work.
- e. The open-ended nature of the project motivated me to do my best work.

The students were also asked to provide their perception in regards to example behaviors of the entrepreneurial mindset with questions "During the course of this project, to what extent did you:"

- f. Explore a contrarian view of accepted (i.e., typical) solutions.
- g. Identify an unexpected opportunity for your design.
- h. Create extraordinary value for a customer or stakeholder.
- i. Integrate information from many sources to gain insight.
- j. Assess and manage risk.
- k. Persist through failure.
- l. Apply creative thinking to ambiguous problems.
- m. Apply systems thinking to complex problems.
- n. Evaluate economic drivers.
- o. Examine a customer's or stakeholder's needs.
- p. Understand the motivations and perspectives of others.
- q. Convey engineering solutions in economic terms.
- r. Substantiate claims with data and facts.

These questions directly assess student outcomes from Kern Entrepreneurial Engineering Network (KEEN). Answers to the questions were provided in five scales:

- 1. None at all

- 2. Slightly
- 3. On some occasions
- 4. Many times
- 5. Throughout most of the project

Besides the students were also asked about their team dynamics and experience with question:

- s. To what extent did you work as a team?

Answers are provided in 5 scales:

- 1. Almost never
- 2. Rarely
- 3. Sometimes
- 4. Often
- 5. Almost always

B. Assessment in Thermodynamics

The assessment of the first thermodynamics module was done using a fully-developed answer sheet for comparing the student's responses to the desired and expected answers to the assignment, as is typically employed in standard engineering courses. Assessment of the second module (still being developed, as previously mentioned) contains greater computational emphasis for basic application skills in the pneumatics industry. The assessment of this second module will be done using a grading rubric, based on the pre-determined educational knowledge outcomes and computational understanding considered important for basic knowledge in the pneumatics industry. Once the rubric is developed, it can be used to compare the student's responses to the desired responses in the rubric to assure answer compliance.

IV. RESULTS AND DISCUSSION

A. Fluid Mechanics

While working on the PBL/EML project, students were exposed to fluid power and related applications, which is traditionally not covered in this course. Some of the student work samples are shown in Figure 1 and Figure 2.

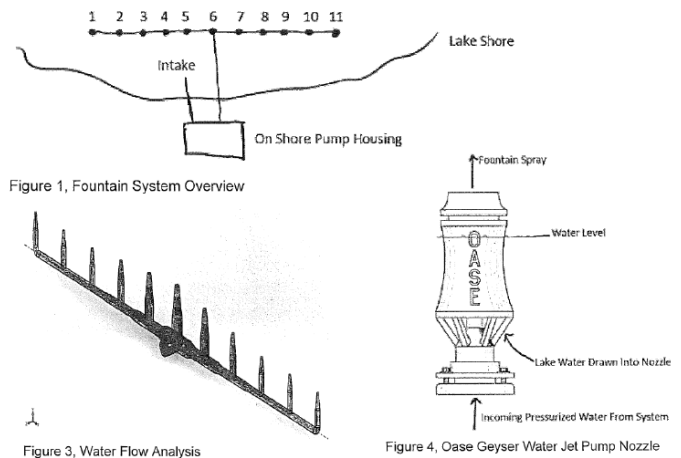
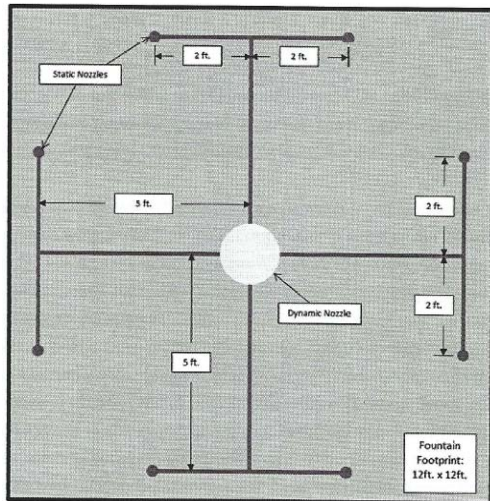
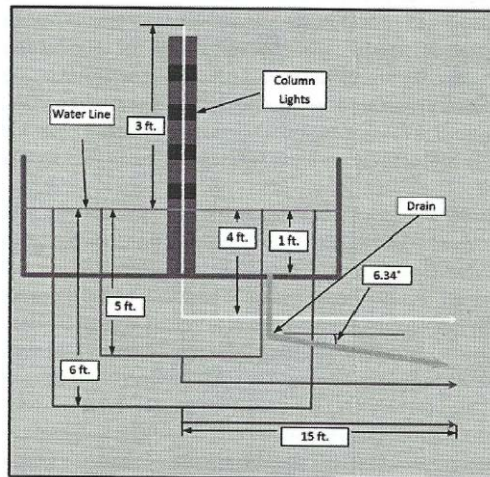

Fig. 1. Student work sample from course section 1



(a)



(b)

Fig. 2. Student work sample course section 2; (a) Comprehensive schematic of the overview of fountain; (b) Comprehensive schematic of the fountain piping system

Survey results assessing students' perception about their own technical learning are presented in Table I (N = 12 from Fall 2016 and N = 15 from Spring 2017). Each of the ten questions had average student response above 3.0, indicating that the students perceived that the PBL/EML exercise helped them improve their learning on the technical content. The primary purpose of this course is the introduction of technical content and these results indicate that the PBL/EML exercise is of value to that aim in the perception of the students.

The two technical items with highest student perceived performance (consistently in both Fall 2016 and Spring 2017) are item "i" – Identifying the components and functions of a pipe system (mean 4.33 and 4.27) and item "iv" - Analyzing the function of various flow components (pumps, valves, etc.) (mean 4.36 and 4.20). The results also indicate that through this activity the students practiced synthesizing information from different topics learned during the course and applying it to

solve a real-world fluid mechanics system (mean 3.83 and 4.07 in item "ix").

TABLE I. SURVEY RESULTS ASSESSING TECHNICAL SKILLS IN THE FLUID MECHANICS COURSE

Question	Fall 2016 (N=12)		Spring 2017 (N=15)	
	Mean	Standard Deviation	Mean	Standard Deviation
i	4.33	0.49	4.27	0.59
ii	3.42	0.90	3.67	1.05
iii	3.92	0.51	4.00	0.76
iv	4.36	0.50	4.20	0.56
v	3.83	0.94	4.07	1.03
vi	4.00	0.95	3.93	0.62
vii	3.75	0.45	3.93	0.70
viii	3.83	0.58	3.80	0.86
ix	3.83	0.72	4.07	0.59
x	3.67	0.65	3.93	0.88

Students' answer to item "ii" - Identifying the components and functions of a hydraulic system - shows the lowest performance among all the ten questions (again consistently in both semesters). However, it should be noted that elements of "fluid power" are usually not specifically covered in detail in the classroom of a standard Fluid Mechanics course. The students' score of 3.42 implies that the students were at least exposed to the concepts and application of hydraulic systems during this design exercise. The students also admitted that this project required them to do a lot of research and reading in this area.

Student deliverables were directly assessed using a general PBL rubric, as described in section III. Results are provided in Table II; note that the rubric scales from 0 to 4. While the general rubric was not aligned with the survey dimensions, the instructor scoring the reports was applying it in the context of Fluid Mechanics and the assigned PBL/EML activity. All the nine items "identification of problem", "data collection", "representing data", "verify and evaluate information", "draw conclusions and make appropriate applications", "justify and support decisions, strategies, findings, and solutions", "communicate purpose and/or main idea for audience", "organization", and "supporting details and/or visuals" were all scored with mean 3.00 or higher, indicating "proficient demonstration". Combined with student surveys of perceived learning, the direct assessment indicates that the course is successful in teaching Fluid Mechanics concepts through the use of a PBL/EML module that also embeds fluid power concepts.

TABLE II. DIRECT ASSESSMENT RESULTS FOR FLUID MECHANICS COURSE

Criteria	Mean	Standard Deviation
Identification of problem	3.35	0.53
Data collection	3.15	0.53
Representing data	3.30	0.59
Verify and evaluate information	3.00	0.67
Draw conclusions and make appropriate applications	3.30	0.48
Justify and support decisions, strategies, findings and solutions	3.20	0.54
Communicate purpose and/or main idea for audience	3.90	0.32
Organization	3.55	0.55
Supporting details and/or visuals	3.15	0.78

Table III shows student feedback about perceived demonstration of entrepreneurial mindset during the Fluid Mechanics PBL/EML activity. The design project allowed students to practice various dimensions of the entrepreneurial mindset. For each general question (a to e), the average result was above 3.0, indicating general student satisfaction with the project and their results. For each entrepreneurial mindset sample behavior (f to r), the average results was at or above 3.0, indicating that the students perceived themselves to have demonstrated that behavior at least “sometimes”. Thus, the PBL/EML activity succeeded in fostering the entrepreneurial mindset.

The activity particularly addressed the student outcomes of “integrate information from many sources to gain insight” and “substantiate claims with data and facts” (average feedback of 3.83 in Fall 2016 and 3.80 in Spring 2017 to survey questions “i” and “r”). It is also clear that this highly collaborative activity facilitates team work and forces students to work together (average feedback of 3.83 in Fall 2016 and 4.33 in Spring 2017 to survey question “s”). The students did not feel that they created extraordinary value (item “h”). There are likely two explanations for this. First “extraordinary” is a strong term. This is the first experience students have had designing an entire fountain; they certainly would feel they could design a better one with more experience and/or with more expert guidance. Second, the students feel time pressure at the end of the semester with multiple deadlines looming from all of their coursework. The students likely felt that they could have produced a better fountain if they could have devoted full-time to its development.

TABLE III. SURVEY RESULTS FOR ENTREPRENEURIAALLY MINDSED LEARNING IN THE FLUID MECHANICS COURSE

Question	Fall 2016 (N=12)		Spring 2017 (N=15)	
	Mean	Standard Deviation	Mean	Standard Deviation
a	3.67	0.78	3.87	0.83
b	3.67	0.89	4.27	0.80
c	3.50	0.90	3.64	0.63
d	3.67	0.78	3.79	0.70
e	3.75	0.75	3.53	0.92
f	3.75	0.97	3.33	0.82
g	3.17	0.72	3.73	0.80
h	3.00	0.74	3.27	0.96
i	3.83	0.83	3.80	0.68
j	3.17	0.72	3.20	0.86
k	3.50	0.90	3.57	0.94
l	3.50	0.52	3.80	0.77
m	3.25	0.75	3.53	0.99
n	3.42	0.67	3.20	1.01
o	3.58	0.79	3.87	0.64
p	3.50	0.80	3.73	0.70
q	3.75	0.87	3.73	0.80
r	3.83	0.94	3.80	0.77
s	3.83	1.19	4.33	0.62

Many written comments from students described their learning experience through this PBL/EML project. Most mentioned that they liked applying what they are learning from class to real-world problem solving, and they appreciated the open-ended nature of the problem, which are directly addressing survey questions “d” and “e”. Several student comments are listed as examples:

- “It was realistic and I could apply what we're learning directly to the problem. It relied on using a lot of references from the book directly instead of relying on outside sources... for what I was struggling to work with. My partner was very good at helping me understand.”
- “This project made us think critically about what will happen to water flow under certain conditions. For example, pressure loss, flow rates through different size pipes.”
- “It is not limited in textbook so that the question is more open and combined with real life applications.”
- “If a hydraulic system is required, we should spend some class time discussing how one works and how to find the losses within one of those.”

- "We were able to be creative. The project was open to how we wanted to design the system."
- "I liked how it incorporated many aspects of the fluid mechanics curriculum. It used many chapters to come up with an end result that could be related to the real world."

B. Thermodynamics

Initial reviews of the first thermodynamics module from students was positive. All eighteen students in this class successfully completed the assignment. The authors, however, have not included examples of student responses because none of the eighteen students in this class agreed to allow their answers from their work to be shown as evidence in this paper. The authors can say, however, that student responses did indicate that the subject of pneumatics was completely new to the majority of students in the class. Some had knowledge of air-driven tools, and compressor air systems, but they did not at all see those systems as part of pneumatic technologies. Once students related pneumatic systems to technology that they did have knowledge of, they were able to better grasp the broader concepts of pneumatics. In future efforts relating to thermodynamics, the authors will incorporate topics such as air-driven tools to better introduce the field of pneumatics.

V. CONCLUSIONS

Problem-based learning and entrepreneurially minded learning modules were developed and implemented in Thermodynamics and Fluid Mechanics courses to teach core technical concepts, engage students in the area of fluid power and create awareness of related career opportunities, and foster an entrepreneurial mindset. Both direct and indirect assessment were implemented in Fall 2016 and Spring 2017 to evaluate students' technical learning as well as the development of an entrepreneurial mindset. The results show positive feedback in all target outcomes – students learned technical skills, explored fluid power content, and demonstrated sample behaviors associated with an entrepreneurial mindset.

ACKNOWLEDGMENT

The authors thank the National Fluid Power Association (NFPA) for sponsoring the presented work and the Kern Entrepreneurship Education Network (KEEN) for supporting the course modification program at Lawrence Tech.

REFERENCES

- [1] D. Carpenter, K. Hayes, C. Ward and A. L. Gerhart, "Assessment and Evaluation of a Comprehensive Course Modification Plan," *The Journal of Engineering Entrepreneurship*, vol. 2, no. 2, 2011.
- [2] A. L. Gerhart and D. D. Carpenter, "Campus-wide Course Modification Program to Implement Active & Collaborative Learning and Problem-based Learning to Address the Entrepreneurial Mindset," in *Proc. 2013 ASEE Annual Conference and Exposition*, Atlanta, GA, 2013.
- [3] A. L. Gerhart and D. E. Melton, "Entrepreneurially Minded Learning: Incorporating Stakeholders, Discovery, Opportunity Identification, and Value Creation into Problem-Based Learning Modules with Examples and Assessment Specific to Fluid Mechanics," in *Proc. 2016 ASEE Annual Conference & Exposition*, 2016.
- [4] A. L. Gerhart and R. W. Fletcher, "Project-Based Learning and Design Experiences in Introduction to Engineering Courses: Assessing an Incremental Introduction of Engineering Skills," in *Proc. 2011 ASEE Annual Conference & Exposition*, 2011.
- [5] A. L. Gerhart, D. D. Carpenter, R. W. Fletcher and E. G. Meyer, "Combining Discipline-specific Introduction to Engineering Courses into a Single Multidiscipline Course to Foster the Entrepreneurial Mindset with Entrepreneurially Minded Learning," in *Proc. 2014 ASEE Annual Conference & Exposition*, 2014.
- [6] J. A. Mynderse, A. L. Gerhart, L. Liu and S. Arslan, "Multi-course Problem-based Learning Module Spanning Across the Junior and Senior Mechanical Engineering Curriculum: Mechatronics, Fluid Mechanics, and Heat Transfer," in *Proc. 2015 ASEE Annual Conference & Exposition*, Seattle, 2015.
- [7] L. Liu, J. A. Mynderse, A. L. Gerhart and S. Arslan, "Fostering the Entrepreneurial Mindset in the Junior and Senior Mechanical Engineering Curriculum with a Multi-Course Problem-based Learning Experience," in *Proc. 45th ASEE/IEEE Frontiers in Education Conference*, 2015.
- [8] J. A. Mynderse and J. N. Shelton, "Implementing Problem-Based Learning in a Senior/Graduate Mechatronics Course," in *Proc. 2014 ASEE Annual Conference and Exposition*, Indianapolis, 2014.
- [9] J. A. Mynderse and J. Shelton, "Assessment of an Improved Problem-Based Learning Implementation in a Senior/Graduate Mechatronic Design Course," in *Proc. 2015 ASEE Annual Conference and Exposition*, Seattle, 2015.
- [10] K. A. Smith, S. D. Sheppard, D. W. Johnson and R. T. Johnson, "Pedagogies of Engagement: Classroom-Based Practices," *Journal of Engineering Education*, vol. 94, no. 1, pp. 87-101, 2005.
- [11] M. Prince, "Does Active Learning Work? A Review of the Research," *Journal of Engineering Education*, vol. 93, no. 3, pp. 223-331, 2004.
- [12] Kern Entrepreneurial Engineering Network, "Entrepreneurial Mindset 101," [Online]. Available: <http://engineeringunleashed.com/keen/em101/>.

Appendix G-3: Article Published at 2018 ASEE Conference



Assessment of Fluid Power Modules Embedded in Junior Level Thermodynamics and Fluid Mechanics Courses

Dr. Liping Liu, Lawrence Technological University

Liping Liu is an associate professor in the A. Leon Linton Department of Mechanical Engineering at Lawrence Technological University. She earned her Ph.D. degree in Mechanical Engineering from University of Illinois at Urbana-Champaign in 2011. Her research focuses on thermal sciences and energy systems, with special interest in addressing transport phenomena in energy processes. She is a member of ASEE, ASME, and SAE International.

Dr. James A. Mynderse, Lawrence Technological University

James A. Mynderse, PhD is an Assistant Professor in the A. Leon Linton Department of Mechanical Engineering at Lawrence Technological University. His research interests include mechatronics, dynamic systems, and control with applications to piezoelectric actuators, hysteresis, and perception. He serves as the faculty advisor for the LTU Baja SAE team.

Dr. Robert W Fletcher, Lawrence Technological University

Robert Fletcher joined the faculty of the Mechanical Engineering Department at Lawrence Technological University in the summer of 2003, after two decades of various industry engineering positions in research, and product development.

Dr. Fletcher earned his Bachelor of Science Degree in Chemical Engineering from the University of Washington, in Seattle, and the Master of Science and Ph.D. degrees in Chemical Engineering, both from the University of Michigan.

He teaches a number of alternative energy courses at Lawrence Tech. Dr. Fletcher and his student research team is focusing on energy usage and efficiencies of several traditional and alternative energy systems.

Dr. Andrew L Gerhart, Lawrence Technological University

Andrew Gerhart, Ph.D. is an Associate Professor of Mechanical Engineering at Lawrence Technological University. He is actively involved in ASEE, the American Society of Mechanical Engineers, and the Engineering Society of Detroit. He serves as Faculty Advisor for the American Institute of Aeronautics and Astronautics Student Chapter at LTU, chair of the First Year Engineering Experience committee, chair for the LTU KEEN Course Modification Team, chair for the LTU Leadership Curriculum Committee, supervisor of the LTU Thermo-Fluids Laboratory, coordinator of the Certificate/Minor in Aeronautical Engineering, and faculty advisor of the LTU SAE Aero Design Team. Dr. Gerhart conducts workshops on active, collaborative, and problem-based learning, entrepreneurial mindset education, creative problem solving, and innovation. He is an author of a fluid mechanics textbook.

Assessment of Fluid Power Modules Embedded in Junior Level Thermodynamics and Fluid Mechanics Courses

Abstract

In collaboration with the National Fluid Power Association (NFPA), the faculty at Lawrence Technological University developed and implemented fluid-power based modules (i.e., classroom exercises) for two BS Mechanical Engineering (BSME) core courses: Thermodynamics and Fluid Mechanics. The project aims to teach students the basic theories and concepts in fluid power and expose them to real-world hydraulic and pneumatic applications. Modules designed for the Fluid Mechanics course focus on addressing hydraulics related applications, and modules designed for the Thermodynamics course focus on pneumatic systems. Fluid power modules include homework to be completed individually, in-class active and collaborative learning (ACL) exercises, and problem-based learning (PBL) team projects with entrepreneurially minded learning (EML) components. However, all modules are intended to foster a better student understanding of the theory, practices, and career opportunities associated within the fluid power industry.

Starting in the Fall of 2016, the authors developed the modules and implemented them in multiple sections (taught by different instructors) of Thermodynamics and Fluid Mechanics courses in three consecutive semesters (Fall 2016, Spring 2017, Fall 2017). Pre and post surveys were conducted to gauge the impact on student learning on the fluid power content before and after the designed activities. Both direct and indirect assessment tools were developed and data were collected. This paper focuses on reporting the assessment results in both courses and making recommendations for future improvements of the modules.

Introduction

In collaboration with the National Fluid Power Association (NFPA), the faculty at Lawrence Technological University are incorporating fluid power theory and applications into the Bachelor of Science in Mechanical Engineering (BSME) curriculum. Two core courses – Thermodynamics and Fluid Mechanics – were selected for this work. In the previous curriculum, pneumatics and hydraulics (i.e., fluid power) often received little to no coverage. The work aims to teach students fluid power terminology, basic theories, and concepts as well as to expose students to real-world hydraulic and pneumatic applications. Building on initial work [1], the present study adds indirect assessment for both courses, previously unavailable direct assessment in Thermodynamics, and additional data points for indirect and direct assessment in Fluid Mechanics.

Fluid-power based modules for Fluid Mechanics and Thermodynamics courses were developed for potential continued future use that utilize active and collaborative learning (ACL), problem-based learning (PBL), and entrepreneurially-minded learning (EML) techniques to teach core BSME content while also creating awareness and engaging students in the area of fluid power.

Active learning requires that students participate and discuss issues or work problems in the classroom, rather than listening passively to a lecture. If students informally assist one another in this process, the technique is deemed to be collaborative learning [2]. PBL builds on ACL by introducing engaging real-world problems for students to solve as part of a group [2]. A new twist on PBL is the inclusion of student skills associated with an entrepreneurial mindset, such as integrating information from many sources to gain insight and/or identifying unexpected opportunities to create value. The resulting EML activities emphasize “discovery, opportunity identification, and value creation with attention given to effectual thinking over causal (predictive) thinking” [3].

Atman et al. [4] reported on the Academic Pathways Study to address research questions about student skill development, engineering identity, education, and entrance into the workplace. Among other findings about student perceptions of design in the Academic Pathways Study final report, many students feel unprepared for capstone design projects and wish capstone occurred earlier in the curriculum [4]. Another finding was that students engaged in design projects generally do not consider broad context [4]. A thrust of the current college-wide curricular modification is the inclusion of PBL and EML in the junior year, such as the present work. This should positively impact capstone design experiences in senior year by providing additional smaller-scale design experience (PBL and EML) and encouraging students to consider all stakeholders and the broader context of their work (EML).

Litzinger et al. [5] reviewed studies on the development of engineering expertise and connected that development to effective learning experiences. Effective learning experiences are those that “support the development of deep understanding organized around key concepts and general principles, the development of skills, both technical and professional, and the application of knowledge and skills to problems that are representative of those faced by practicing engineers” [5]. PBL is an effective learning experience that provides practice with complex problem solving outside of the context of a capstone experience. One study of employer evaluations indicated that PBL experiences improved graduates’ problem solving skills [5]. From other works, PBL activities can substantially improve long-term student learning [6, 7, 8] and skill development [8]. Cooperative learning promotes academic success, quality of relationships, and self-esteem [9].

Problems presented to students as PBL activities must be authentic, which can be difficult for instructors to create. Jamaludin et al. [10] reviewed the studies on PBL problem creation and merged design problem criteria into five principles. From these principles, the PBL problem must be authentic and realistic, constructive and integrated, of suitable complexity, promote self-directed learning and lifelong learning, and stimulate critical thinking and metacognitive skills. EML activities pose an additional complication in the first principle as the customer must also be real or realistic. Jamaludin et al. provide a process for developing a PBL problem rooted in the learning objectives. The Fluid Mechanics EML presented here was developed in a very similar manner.

This work builds on the multi-year effort at Lawrence Tech to incorporate ACL, PBL, and EML into the engineering curriculum [11, 12, 3]. These courses span the curriculum from multidisciplinary Introduction to Engineering [13, 14] to undergraduate modules [15, 16, 17] to graduate level mechatronic design [18, 19]. As a partner school of the Kern Entrepreneurial

Engineering Network (KEEN), Lawrence Tech defines the entrepreneurial mindset in terms of the KEEN framework - Curiosity, Connection, and Creating Value, which is usually called the three C's framework [20]. In each of the three items, there are many example student behavior that are desired to be observed during the students' work. For example, Curiosity is demonstrated by "explore a contrarian view of accepted solutions" and Creating Value is demonstrated by "identify unexpected opportunities to create extraordinary value".

The entrepreneurial mindset is not the same as entrepreneurship. The entrepreneurial mindset is the application of the "three Cs" to engineering practice and not necessarily the creation of new business. Inclusion of entrepreneurial education is a valuable addition to the traditional engineering curriculum [21, 22, 23] and aligns with portions of ABET Criterion 3a-k [24].

The rest of this paper is organized as follows. First, courses used in this work are introduced. Next, the detailed course modules are described. Then the methods of assessment are introduced. Finally the assessment results in each course are presented and discussed, and the conclusions are summarized.

BSME Courses Modified

This work focuses on two BSME core courses: Thermodynamics and Fluid Mechanics. A portion of the BSME curriculum is shown in Figure 1 to illustrate the locations of these courses. Also shown in the curriculum are free-choice technical electives. One of the participating faculty was also assigned to teach two technical elective courses (Introduction to Thermal Systems and Applied Thermodynamics). Having already developed materials for Thermodynamics, this faculty member also assigned the same Thermodynamics student activities to students enrolled in Introduction to Thermal Systems and Applied Thermodynamics. Data was collected for both of these courses in addition to the planned Thermodynamics and Fluid Mechanics sections.

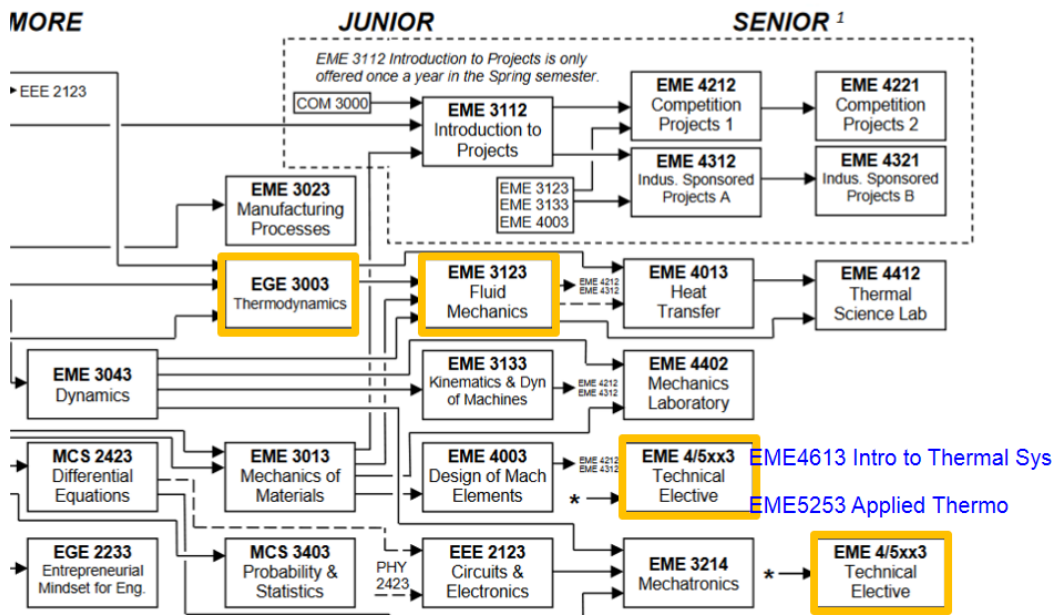

Figure 1 Courses with modified content highlighted in the BSME curriculum

Through 2016 Fall to 2017 Fall, the developed modules were implemented to introduce students into the area of fluid power. Eight different instructors were involved and a total of 239 students were exposed, as shown in Table 1. Results in different courses are presented in sections below.

Table 1 Course sections covered and number of students introduced to fluid power

Semester	Course	# of Students
2016 Fall	Thermodynamics (Section 01)	18
	Thermodynamics (Section 02)	18
	Fluid Mechanics (Section 01)	17
	Fluid Mechanics (Section 02)	8
2017 Spring	Fluid Mechanics (Section 01)	30
	Fluid Mechanics (Section 02)	34
2017 Fall	Thermodynamics (Section 01)	9
	Thermodynamics (Section 02)	19
	Thermodynamics (Section 03)	30
	Fluid Mechanics (Section 01)	12
	Fluid Mechanics (Section 02)	14
	Introduction to Thermal Systems	10
	Applied Thermodynamics	20
	TOTAL	239

Description of the Course Modules

Activities in Thermodynamics

The thermodynamics course (course number EGE 3003) that implemented the pneumatics module is typically taken in the junior year and is predominantly taken by mechanical engineering students. Some civil and architectural engineering students were also enrolled during this assessment. This course is often the first truly analytical thermodynamics engineering course these students take with the extensive introduction and rigorous development of the abstract concepts of enthalpy and entropy. As a result, there are many new concepts to students that are presented and developed in this course. Another key point is that many of these students have not had industry experience and typically have not seen advanced industrial automation or manufacturing technology that could employ pneumatic systems.

With the recognition that many of these junior-year engineering student may be unaware of the wide use of pneumatic systems in manufacturing and are often ignorant of pneumatic technology, there were three goals proposed for the pneumatic modules in this course. First, students were introduced to the basics of pneumatic technology, pneumatic terminology, and pneumatic concepts. Second, students were introduced to these concepts in order to gain an understanding of how pneumatics can be utilized and employed in industry, and to learn the basic components of pneumatic systems. Lastly, to address one of the NFPA goals for the funding grant, we wanted students to realize that there are indeed worthwhile engineering employment opportunities available to them in the pneumatics industry, and that these jobs can provide intellectually satisfying and financially beneficial life-long employment opportunities.

There is always a challenge in adding more instructional materials to a course already “full” of content. To navigate through the added content the first two goals were addressed outside of class using online resources such as YouTube videos. To meet the third goal students were directed to the NFPA website and reviewed the related employment information it contains. These are detailed in the assignment (or module) A which is shown in Appendix A.

A second analytical computational assignment was developed to help expand a student's knowledge of pressurized air and transitioning from ideal gas operational ranges to non-ideal gas pressure ranges and how those two ranges can impact pneumatic performance. These are detailed in the assignment (or module) B which is shown in Appendix B.

Activity in Fluid Mechanics

Fluid Mechanics is a junior-level course that directly follows Thermodynamics in the BSME curriculum. Students usually have more understanding or experience with the concepts of fluid power. Therefore, a larger scale problem-based learning project with more complexity was assigned. Students were tasked to work in a self-selected team of three to design a fountain with hydraulically controlled nozzles. Each team was required to submit one technical report describing their detailed design. A brief description of the assignment is provided below, with more detailed information given in Appendix C.

Fountain with Hydraulically Controlled Nozzle System

Three and half years ago, your rich uncle, Mortimer, purchased a large tract of land in the Upper Peninsula of Michigan. It has a magnificent wilderness resort lodge, which had been abandoned years ago and had fallen into a dilapidated state. The lodge is known as the Overlook Hotel. After Uncle Mortimer restored the Overlook, his guests come to enjoy forest hiking, mountain biking, and a variety of other outdoor pursuits. Some just come to enjoy the peace and quiet at the hotel. Since the Overlook is located on a rocky hillside 300 vertical feet above the lake (which is what the hotel “overlooks”) and 2200 ground feet from the lake’s edge, he installed a chair lift for downhill skiing to draw customers during the brutally cold winter months. He has also installed a surface called “Snowflex” so that skiers can enjoy the slopes in both summer and winter. Yet with all that, there is one more element that Uncle Mort feels would really enhance his hotel: a mesmerizing fountain display. He has seen the fabulous Bellagio Fountains, and enjoys the interesting fountain in the McNamara Terminal of the Detroit Metropolitan Airport. He wants something that will be appropriate for his wilderness resort. After learning of your vast new knowledge of fluid mechanics, he has asked you to design a fountain. As a member of the National Fluid Power Association, Uncle Mort requires that one or more of the nozzles is controlled by a hydraulic system which will allow the nozzle(s) to move the water jet(s) in some sort of pattern. The water jet(s) from the movable nozzle(s) must be high enough pressure to allow for a sufficient water height. He wants this fountain to be an attraction for his customers. You will need to consider a water delivery system, filter(s), a piping system, hydraulic system, and other components for this fountain.

In the process of completing this PBL/EML, students must gather information from their customer, Uncle Mort, role-played by the course instructor. The students will not only solve the

technical problem, but must communicate their solution in economic terms. On top of all the details about their technical design, students are asked to provide an estimate on the budget of their proposed fountain (including the components and operating costs). Students should also be looking for unexpected opportunities that will enhance the value for their customer. A few of these opportunities are “hidden” within the problem statement. For example, the extended hillside above the lodge can be used for a water tank and additional water pressure, decreasing pump size at the lake. In addition, because of the low power needed for hydraulic control, water can be used for the hydraulic fluid instead of more expensive (and complex) hydraulic fluid.

The authors would like to point out that most Mechanical Engineering students at Lawrence Tech are very familiar with this stakeholder, rich Uncle Mortimer, because of his “appearance” in many PBL projects. “He” is vastly rich and had all kinds of crazy ideas of designing new products or systems for his business or recreational purposes. As the customer of many PBL/EML projects he becomes well known among the faculty and students in the department.

The PBL design exercise was assigned during the last four to five weeks of the semester, because the students need to integrate all the material they learned in order to complete the calculations and make proper decisions. Students were encouraged to discuss with each other and make their own member selections to form their team. The students who don’t or can’t find a team after a certain date will be assigned into one by the instructor. Most of the teams have three members, but depending on the total number of students in that section some team may end up with two or four members. This is mostly an outside-of-classroom assignment, but staging in class was conducted each week to make sure the students are in progress and can get help whenever they need.

Through 2016 Fall to 2017 Fall semesters, a total of six sections of Fluid Mechanics course were offered (two sections per semester), which were taught by three different instructors. The PBL project was assigned in each and every of the sections. However, the students got very different requirements about the design because their customer (instructor) has his/her preferences.

Assessment in Thermodynamics

Before each of the two thermodynamics assignments were created, a list of educational outcomes and learning objectives for each was developed. For the first assignment these listed objectives were, admittedly, somewhat basic, but still deemed very important to give the student a foundational understanding on the topic. These outcomes included the following:

1. Providing the student an opportunity to physically see simple but very clear mechanical operations of a pneumatic systems.
2. To have the student learn about, assess and review the advantages of a pneumatic system.
3. To give the student an opportunity to compare a simple pneumatic system to that of a possible manually done operation.
4. To have the student see, review and assess a pneumatic power operation that they might not have considered as a pneumatic application.

5. To review and list the various components required for a standard pneumatic power system.
6. For the student to access, list and review possible engineering applications, the engineering field of, and possible employment opportunities within the pneumatics field from the National Fluid Power Association (NFPA) organization's web site. It was deemed important that students know about the existence of such a professional organization and its available resources.

After the learning objectives were established then the assignment called Module "A" was developed (and is provided in the Appendix of this paper). For students to see working pneumatic systems various YouTube videos, that are easily accessible on the web, were listed for student review. Student work was evaluated using a fully-developed answer sheet for comparing the student's responses to the expected answers to the assignment.

For the second assignment a list of learning objectives were again generated. These outcomes included the following:

1. Provide the student an opportunity to gain a more detailed working understanding regarding the features of a pneumatic system's air compressor and what goes into the proper selection of an air compressor equipment.
2. To assess computationally if air, compressed to a given pressure, typical of pneumatic conditions, is or is not an ideal gas.
3. Apply the required equations to calculate the work required to compress a given volume of air.
4. Calculate the changes in compressed gas pressure after a gas heats, due to compression to a given volume, then cools to a new ambient temperature at that same volume.

Assessment of the second assignment also employed a fully developed grading sheet based on the above listed learning outcomes, and a computational understanding that were considered fundamental for basic application skills in the pneumatics industry.

The Fall 2016 courses results are not included here because the authors were, unfortunately, not able to obtain permission from the students to use or publish their results. This was deemed acceptable because the first issuance of each module was for evaluation of the questions themselves. In Spring 2017 no faculty members affiliated with the grant taught any of the thermodynamics class sessions, so the modules were not assigned and no data were collected for those classes. For the Fall 2017 semester five class sessions were issued thermodynamics modules "A" and "B".

The assessment results for Module "A" are given in Table 3. In the first column of Table 2, a class number is listed. There were 82 students issued the Module "A" assignment, with a total of 80 students completing this assignment.

Based on the student work for the first assignment, it was clear that the overall subject of pneumatics was new to the majority of the students in these classes. Students, however, were

able to quickly relate subject matter to technologies that they did know about with concepts that they did not understand were also part of pneumatic systems. Students clearly understood requirements and components for pneumatic systems. Students were less clear on engineering aspects of compressed gases. Students were able to successfully access and understand NFPA website and pertinent employment opportunities regarding Fluid Power careers.

As would be expected, the graduate student class (Applied thermodynamics) overall did the best on this assignment. An undergraduate thermodynamics section did well, but this class had only eight students and is well taught by an experienced faculty member in the mechanical engineering department. There are some assignable reasons for this class's success: 1) this was an unusually small class with only eight students, 2) the class had an excellent and very experienced thermodynamics instructor, and 3) this class got to this assignment a little later in the semester and may have given students more time to lead-up to the materials covered. (Note that the Introduction to Thermal Systems class did not have the needed compressibility factor chart in their text and, therefore, was not able to complete questions 3a and 3b, and therefore, those questions from that class are not counted in the overall averages.)

The results for Module "B" are summarized in Table 3. In general, students were able to define ideality at elevated temperatures and pressures, although the graduate student class (Applied Thermodynamics) has some students who clearly, and surprisingly, struggled with this. The instructor in this graduate class discussed this with the students in that class and found that several were international students and were new to the US method of assignments and had some trouble with this question. Also, in general students had difficulty computing the work required to compress a gas to high pressures. Students had the most difficulty in computing a new pressure after a gas had cooled. These difficulties are attributed to this often being the student's first exposure computing work using thermodynamic methods and how to compute for pressurized systems.

An area that was disappointing on these assignments was when a written discussion and elaboration was requested; there was an unfortunate brevity in the answers provided by students, with a lack of expansion and development of their answers. Going forward this first assignment will need modification so as to contain more developed wording and questions that explicitly prompts students to provide more discussion and detail. This will assure more comprehensive answers and responses from the students to the prompting questions in the assignment.

In spite of the moderate shortcomings observed in the work of students for these assignments, there were also noted benefits. During short in-class discussions with students after the assignment was issued, there was a real consensus from students that they had gained a great deal of introductory knowledge regarding pneumatics. Some students expressed surprise that there is an entire industry built around pneumatics, and there are viable career opportunities in that field. In these regards, these instructional modules in pneumatics were viewed as successful.

Table 2 A summary of overall results for the Fall 2017 Thermodynamics classes issued the Module A assignment.

		Problem # for Module "A"													Average of Student Scorea for Assignment
		1a	1b	1c	1d	1e	2	3a	3b	4a	4b	4c	4d	4e	
		Points possible for each problem													
		2	2	2	2	2	5	2	2	2	2	2	2	3	30
Class	n	Average points earned for each problem in each class													
Thermodynamics Class #1	17	1.18	1.59	1.76	1.12	1.88	3.47	0.88	1.29	1.71	1.71	1.59	1.65	2.88	22.71
Thermodynamics Class #2	8	1.50	1.88	2.00	1.38	1.88	4.13	1.25	1.88	2.00	2.00	1.75	1.25	2.50	25.38
Thermodynamics Class #3	26	1.38	1.88	1.88	1.50	1.73	3.81	1.12	1.31	1.81	1.88	1.77	1.00	2.42	23.50
Applied thermodynamics Class	19	1.74	1.89	2.00	1.79	1.95	4.63	1.32	1.53	1.84	1.89	1.84	1.68	2.79	26.89
Intro to Thermal Systems Class	10	1.60	1.90	1.90	1.50	1.70	4.70	0.00	0.00	1.90	1.90	1.70	1.60	2.70	23.10
	80	1.46	1.83	1.90	1.48	1.83	4.08	1.13	1.43	1.83	1.86	1.74	1.40	2.65	24.28
	Average %	73.1%	91.3%	95.0%	73.8%	91.3%	81.5%	56.4%	71.4%	91.3%	93.1%	86.9%	70.0%	88.3%	80.9%

Table 3 A summary of overall results for the Fall 2017 Thermodynamics classes issued the Module B assignment.

		Problem # for Module "B"				Average of Student Scorea for Assignment
		2	3a	3b	3c	
		Points possible for each problem				
Class	n	5	8	7	5	25
Thermodynamics Class #1	15	2.87	4.13	1.73	1.73	10.47
Thermodynamics Class #2	7	5.00	7.14	4.43	2.71	19.29
Thermodynamics Class #3	25	4.20	4.88	2.68	2.52	14.28
Applied thermodynamics Class	18	3.00	6.17	2.94	2.33	14.44
Intro to Thermal Systems Class	9	4.67	5.67	2.11	2.00	14.44
	65	3.77	5.35	2.65	2.27	14.04
	Average %	75.4%	66.9%	37.8%	45.4%	56.2%

Assessment in Fluid Mechanics

A survey was distributed to students at the end of the project to acquire their perspective of the learning experience. The first part the survey was targeting about their technical learning. The students were asked to provide their opinion about a series of statements “This project improved my technical skills in:”

- i. Identifying the components and functions of a pipe system.
- ii. Identifying the components and functions of a hydraulic system.
- iii. Making reasonable simplifying assumptions.
- iv. Analyzing the function of various flow components (pumps, valves, etc.)
- v. Identifying and determining major and minor losses in a flow system.
- vi. Predicting pressure and pipe size for series piping systems.
- vii. Determining the required pumping power according to flow requirements.
- viii. Choosing an actual pump that meets the flow requirements.
- ix. Designing a real-world fluid mechanics system.
- x. Reporting the solution to a customer.

Answers were provided as scales from 1 to 5:

1. Strongly disagree
2. Disagree
3. No opinion
4. Agree
5. Strongly agree

The second part of the survey was targeting about the students’ entrepreneurial mindset learning. Students were asked to provide their perception about the project experience to the following statements:

- a. My project design satisfied the customer’s needs and goals.
- b. I consider the results of my project successful.
- c. I found my work on the project to be satisfying.
- d. The real-world application of the project motivated me to do my best work.
- e. The open-ended nature of the project motivated me to do my best work.

They were also asked to give answers using the same scales from 1 to 5, with one the lowest and 5 the highest.

Sample student behavior from the KEEN three C’s framework were also assessed. Students were asked to provide their opinion about a series of statements directly addressing student outcomes from KEEN by answering a series of questions “During the course of this project, to what extent did you:”

- f. Explore a contrarian view of accepted (i.e., typical) solutions.
- g. Identify an unexpected opportunity for your design.
- h. Create extraordinary value for a customer or stakeholder.
- i. Integrate information from many sources to gain insight.
- j. Assess and manage risk.
- k. Persist through failure.
- l. Apply creative thinking to ambiguous problems.

- m. Apply systems thinking to complex problems.
- n. Evaluate economic drivers.
- o. Examine a customer's or stakeholder's needs.
- p. Understand the motivations and perspectives of others.
- q. Convey engineering solutions in economic terms.
- r. Substantiate claims with data and facts.

The answers were provided in five scales:

- 1. None at all
- 2. Slightly
- 3. On some occasions
- 4. Many times
- 5. Throughout most of the project

Following the questions above, the students were also asked about their team dynamics:

- s. To what extent did you work as a team?

Answers were provided in five scales:

- 1. Almost never
- 2. Rarely
- 3. Sometimes
- 4. Often
- 5. Almost always

Direct assessment about students' technical learning was conducted using a PBL rubric that the instructors used to grade their design reports. This score indicates the quality of their design and how much actually they satisfied their customer. Sometimes there is a discrepancy between how much the students believe they learned and how much the instructor determines they learned. One of the contributing factors is that the students' perspective reflected from the survey above is individual, while the technical grading is based on the team report (from a combination of three students). Therefore, some of the opinions were averaged out. More details about the direct assessment are presented in [1].

Students came up with very different designs of the hydraulically controlled water fountains. Many of the students expressed that the open-ended nature of the problem motivated them to do their best work. They also mentioned that they were compelled to learn about hydraulic systems out of the classroom in order to complete the assignments. Two examples of the students' work are shown in Figure 2 and Figure 3.

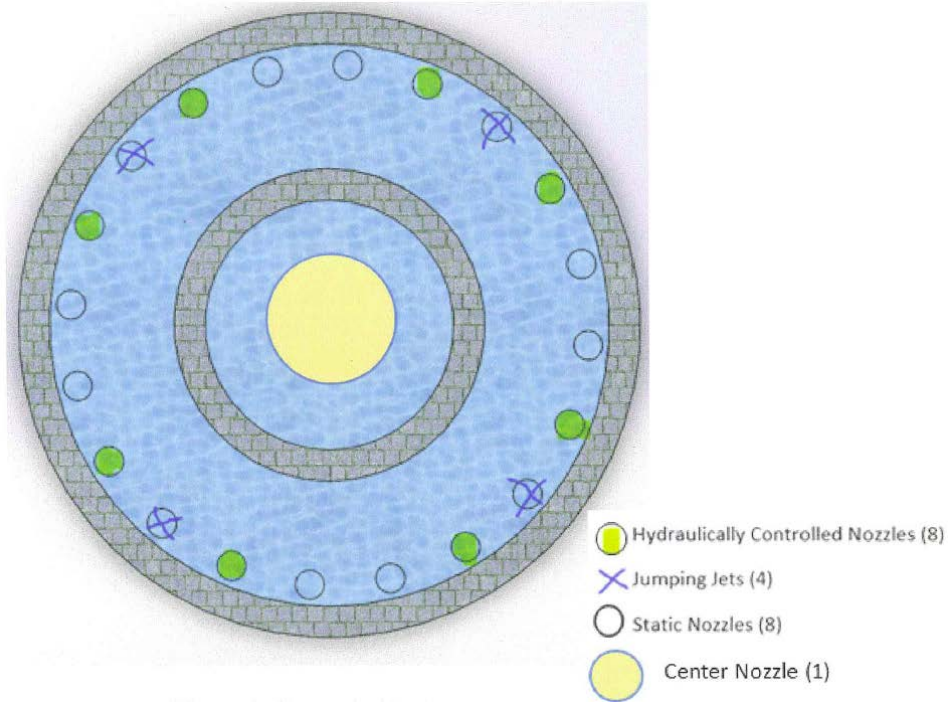

Figure 2 Student work sample 1: Top view of the fountain layout

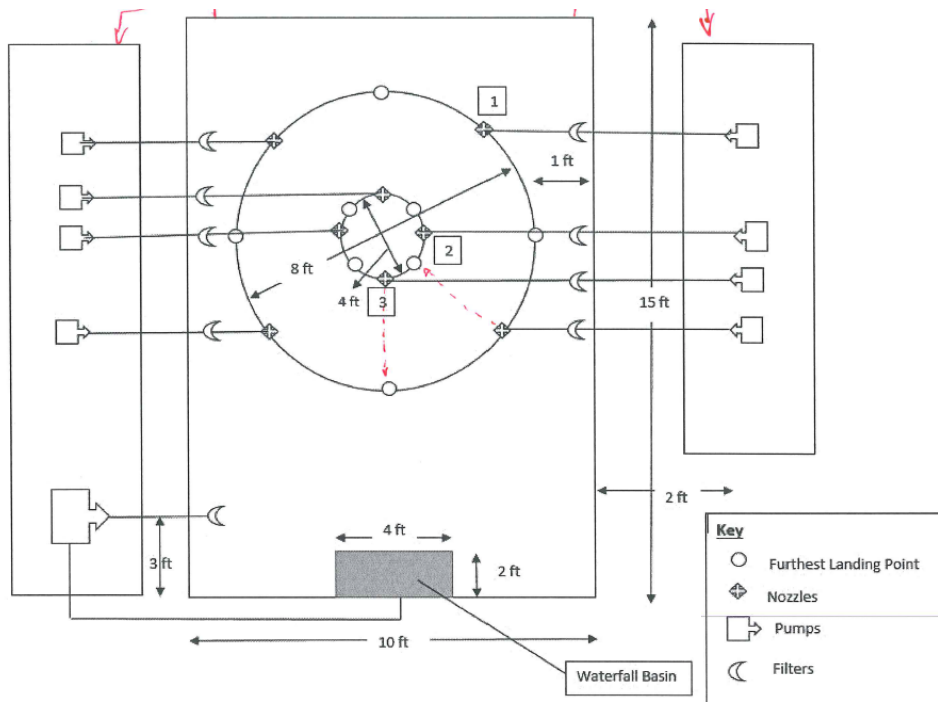

Figure 3 Student work sample 2: Water delivering system of the fountain

The survey results assessing the students' perception about technical learning are presented in Figure 4. The horizontal axis shows the ten survey questions, and the vertical axis shows the average response from all the students' answers. Data from three consecutive semesters were collected and were presented as blue columns, orange columns, and gray columns, respectively. The black bars indicate the standard deviation of the data.

Figure 4 reveals that the results from each semester are relatively consistent, even with different instructors and various student demographics. The average number for all the ten questions is above 3.0, indicating that the students perceived that the problem-based learning exercise helped them improve their learning on the technical content. The two items always with high performance in all the three semesters are item "i" (Identifying the components and functions of a pipe system) and item "iv" (Analyzing the function of various flow components (pumps, valves, etc.)). The results also indicate that through this activity the students practiced synthesizing information from different topics learned during the course and applying it to solve a real-world fluid mechanics system (question "ix").

One item that showed consistently lower results is question "ii" (Identifying the components and functions of a hydraulic system). This was expected because hydraulic systems were never covered in the class lectures. It is the purpose of this PBL assignment to expose students in this area and facilitate their self-learning outside of classroom. Therefore, it is an area that students found challenging. However, the results are still well above 3.0 which indicates sufficient student learning in this fluid power application.

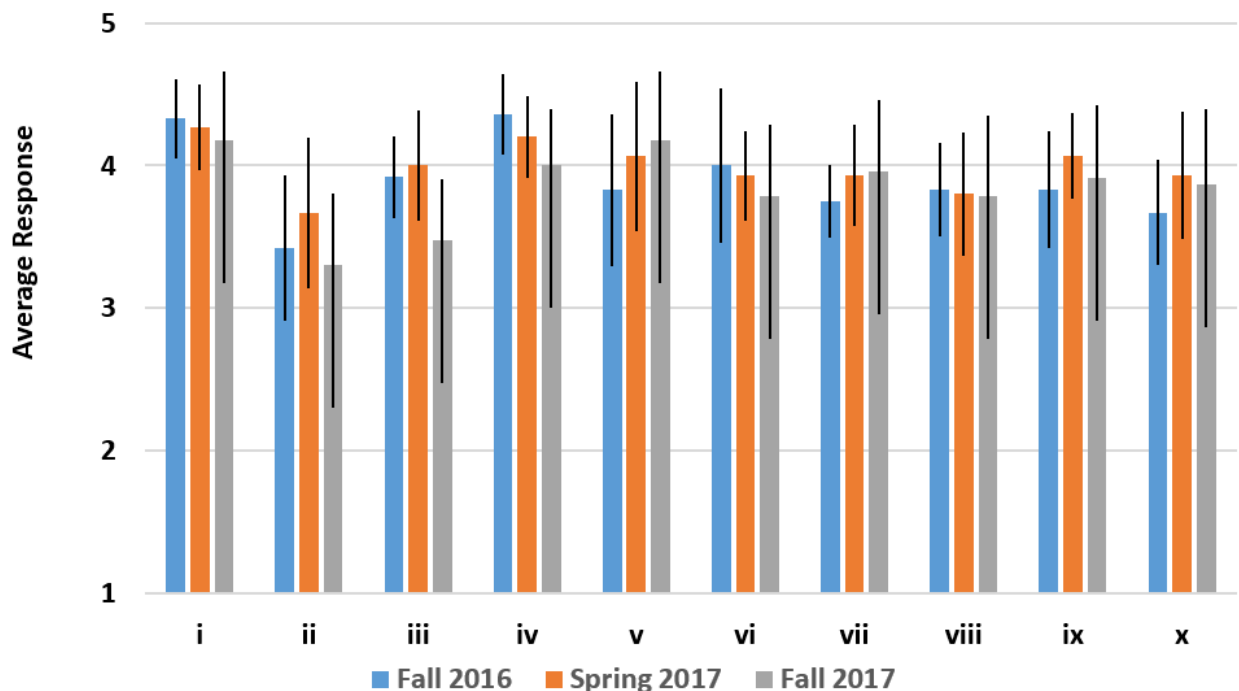

Figure 4 Students' response about technical learning

The data shown in Figure 5 are the student feedback about entrepreneurial mindset learning to the PBL/EML activity implemented in Fluid Mechanics. Again data from three consecutive semesters were collected and were presented as blue columns, orange columns, and gray columns, respectively. As shown in the Figure, the design project allowed students to gain various practice of entrepreneurial skills. Many students considered the results of their projects successful (survey question “b”). The activity particularly addressed the student outcomes of “integrate information from many sources to gain insight” and “substantiate claims with data and facts” (average feedback of 3.83 to survey questions “i” and “r”). It is also clear that this highly collaborative activity facilitates team work and forces students to work together (survey question “s”).

One item that showed consistently lower response is item “h”. The students did not feel that they created extraordinary value, which may be addressed by two reasons. First, “extraordinary” is a very strong term. This is the first experience students have had to design an entire fountain. Many of them felt that they could design a better one with more experience and/or with more expert guidance. Second, the students felt time pressure at the end of the semester with multiple deadlines looming from all of their coursework. The students likely felt that they could have produced a better fountain if they could have devoted full-time to its development.

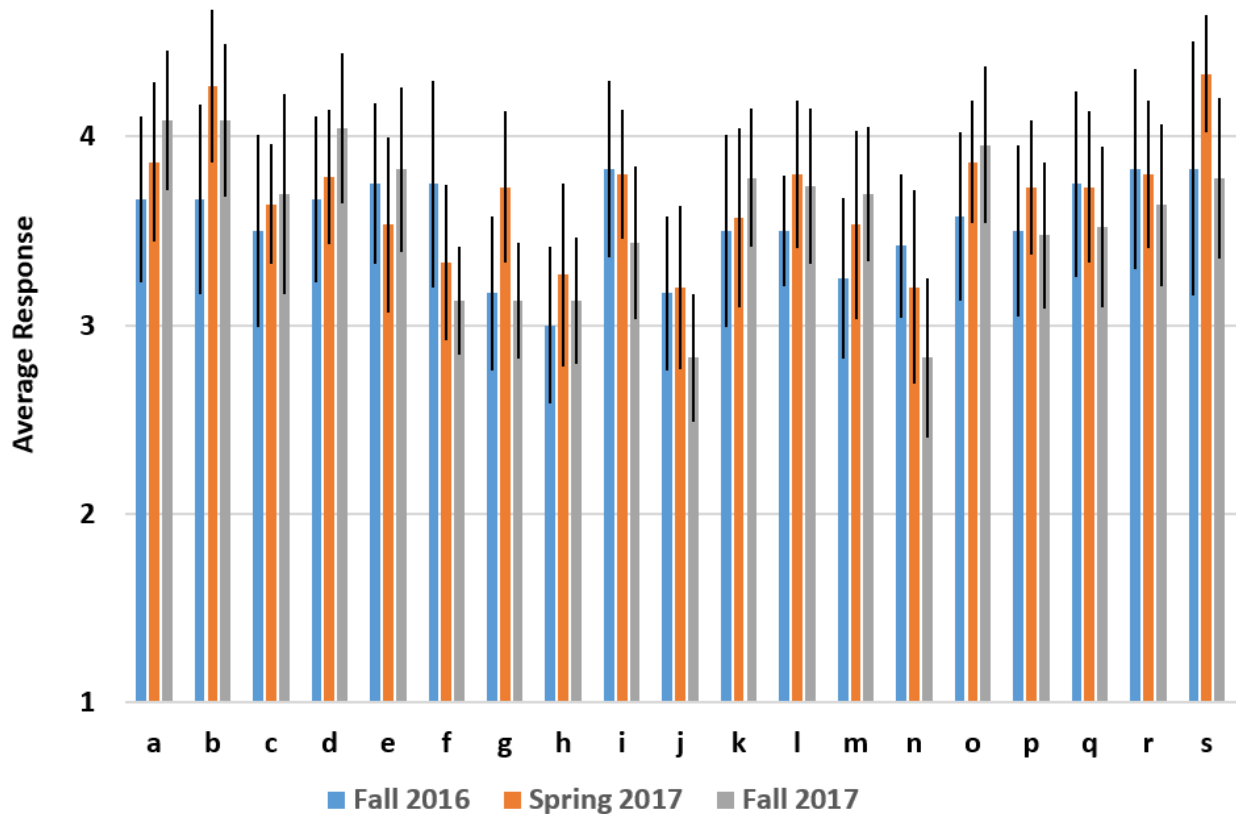

Figure 5 Survey results for entrepreneurial mindset in the Fluid Mechanics Course

Many written comments were received from students sharing their learning experience working on this PBL/EML assignment. Most of the students mentioned that they enjoyed applying the

theories learned to an out-of-classroom design exercise, and they appreciated the open-ended nature of the problem. Some examples of such comments are shown below:

- “I enjoyed the open-endedness of the project, as it allowed for more creativity and real world problem solving.”
- “It was realistic and I could apply what we’re learning directly to the problem. It relied on using a lot of references (not) from the book directly instead of relying on outside... for what I was struggling to work with. My partner was very good at helping me understand.”
- “The project made us think critically about what will happen to water flow under certain conditions. For example pressure loss, flow rates through different size pipes.”

Some students also shared their struggling due to the fact that the element of fluid power is not officially covered in class lectures. It was also observed that some student teams were confused by the difference between fluid power hydraulics and “general hydraulics” such as the use of a pump. This is something that needs to be clarified to students in future classes. Examples of student suggestions are shown below:

- “A little more direction with the hydraulic component. We struggled with that. I guess we could’ve come to you earlier though.”
- “Assign the project earlier in the semester to give students more time to work on it. The turn in deadline came up fast and it would have been nice to have a few more days to complete it.”

Indirect Assessment in All Courses: Student Learning in Fluid Power

Student learning was indirectly assessed with a paired pre/post survey. Both surveys were administered electronically using Google Forms. One advantage of Google Forms for this application was that student email addresses were captured without student entry. Email addresses were used only to connect pre to post surveys. Some students completed the survey more than once. In these cases of duplicate responses, only the last entry was kept.

The pre and post surveys were designed to facilitate measurement of changes in student learning. Contents of the pre and post surveys are shown in Table 4. The pre survey asked students to rate their previous experience with hydraulic and pneumatic systems and provided a space to explain. This question is shown in Figure 6. Both pre and post surveys provided a list of terms and asked the students to identify those that they could define, as shown in Figure 7. The list of definable terms served two purposes. First, the number of definable terms was used as an assessment of comprehension. Second, thinking about the terms was intended to trigger a more accurate self-assessment of comprehension on the following question shown in Figure 8. The post survey asked students to self-assess comprehension both at the beginning of the semester and at the conclusion of the semester. This allowed two deltas to be calculated: pre-post and post-post, as shown in Figure 9.

Table 4 Pre and Post Survey content

Dimension	Pre Survey	Post Survey
Student demographics	Sex, Class	Sex, Class
Previous experience	Rating Explanation	
Overall knowledge	Definable terms	Definable terms
Start of the Semester Understanding	Hydraulic theory and applications Pneumatic theory and applications	Hydraulic theory and applications Pneumatic theory and applications
End of the Semester Understanding		Hydraulic theory and applications Pneumatic theory and applications

Rate your previous experience with HYDRAULIC systems

0 1 2 3 4 5

None Extensive

If you marked an answer other than "None", briefly describe your previous experience with HYDRAULIC systems (school, work, etc.)

Your answer _____

Figure 6 Question about students' previous experience with hydraulic systems

Check the boxes for words for which you could write definition as it relates to fluid power

- | | | |
|--|--|--|
| <input type="checkbox"/> Absorption | <input type="checkbox"/> Amplification | <input type="checkbox"/> Head |
| <input type="checkbox"/> Accumulator | <input type="checkbox"/> Bernoulli's Law | <input type="checkbox"/> Hydraulic Amplifier |
| <input type="checkbox"/> Adsorption | <input type="checkbox"/> Boyle's Law | <input type="checkbox"/> Manifold |
| <input type="checkbox"/> Air Motor | <input type="checkbox"/> Cavitation | <input type="checkbox"/> Pascal's Law |
| <input type="checkbox"/> Air (dried) | <input type="checkbox"/> Charles' Law | <input type="checkbox"/> Poise |
| <input type="checkbox"/> Air (saturated) | <input type="checkbox"/> Circuit | <input type="checkbox"/> Pressure (absolute) |
| <input type="checkbox"/> Air (standard) | <input type="checkbox"/> Compressibility | <input type="checkbox"/> Pump |
| | <input type="checkbox"/> Compressor | <input type="checkbox"/> Reservoir |
| | <input type="checkbox"/> F-R-L unit | <input type="checkbox"/> Return Line |
| | <input type="checkbox"/> Fitting | <input type="checkbox"/> Reynolds Number |
| | <input type="checkbox"/> Flow Rate | <input type="checkbox"/> Servovalve |
| | <input type="checkbox"/> Fluid Friction | <input type="checkbox"/> Specific Gravity |
| | | <input type="checkbox"/> Valve |

Figure 7 List of definable terms (condensed from survey for display purposes).

Rate your current understanding of the THEORY of HYDRAULIC systems:

	0	1	2	3	4	5	
None	<input type="radio"/>	<input type="radio"/>	<input type="radio"/>	<input type="radio"/>	<input type="radio"/>	<input type="radio"/>	Expert

Rate your current understanding of the APPLICATIONS of HYDRAULIC systems:

	0	1	2	3	4	5	
None	<input type="radio"/>	<input type="radio"/>	<input type="radio"/>	<input type="radio"/>	<input type="radio"/>	<input type="radio"/>	Expert

Figure 8 Question to acquire a more accurate self-assessment of comprehension in the specific area

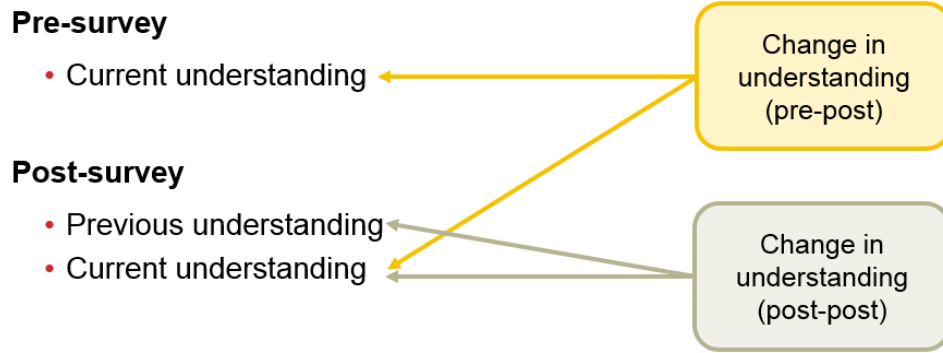

Figure 9 Two deltas were evaluated from the students' feedback: pre-post and post-post

The number of unique responses for each course are shown in Table 5. Due to the small sample sizes, responses from Intro to Thermal Fluids and Applied Thermodynamics are only included in the aggregate.

Table 5 Number of responses to Pre and Post Surveys.

Course	# Completed Pre Survey	# Completed Post Survey	# Completed Pre & Post
Thermodynamics	38	41	34
Fluid Mechanics	26	23	22
Intro to Thermal Fluids	10	7	6
Applied Thermodynamics	18	15	13

First, student self-assessment of prior fluid-power experience was considered. Students rated their experience on a scale from 0 (none) to 5 (extensive), as shown in Figure 10. Most students had no prior experience with hydraulic or pneumatic systems. Among those that had prior experience, most cited work experience as the source.

Figure 11 shows histograms of the number of fluid-power terms that students could define and Figure 12 shows histograms of the change in number of fluid-power terms that students could define. Figure 12 shows an increase in the number of definable terms for both courses considered. This indicates that the fluid power modules are contributing to student knowledge. Also interesting is that some students demonstrated a decrease in the number of definable terms. This is attributed to the effect of the fluid power modules on assisting students to identify misconceptions. These misconceptions may not have been fully corrected.

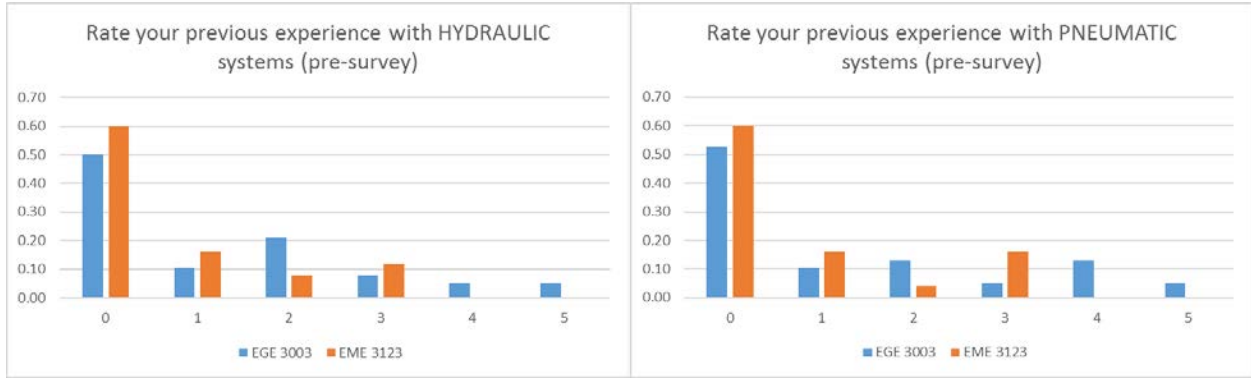

Figure 10 Normalized self-assessment of previous experience on a scale from 0 (none) to 5 (extensive).

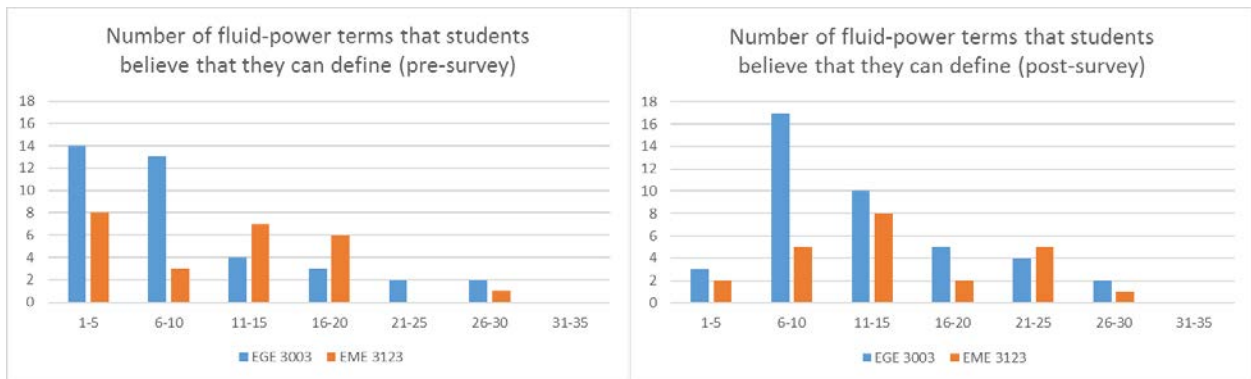

Figure 11 Number of fluid-power terms that students believe that they can define from pre and post survey.

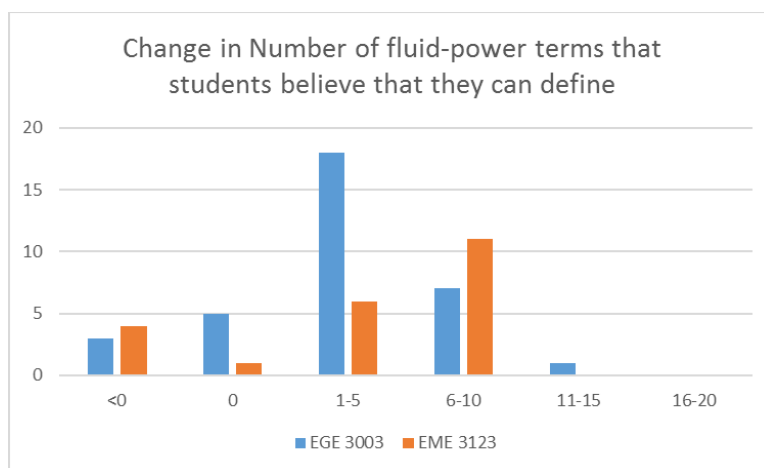

Figure 12 Change in number of fluid-power terms that students believe that they can define (pre to post survey).

Student self-assessment of comprehension was broken down into hydraulic and pneumatic systems with theory and applications for both. Students responded on a range from 0 (none) to 5 (expert) in both the pre and post survey. Normalized responses from the pre-survey are shown in Figure 13 and normalized responses from the post-survey are shown in Figure 14. From the pre-survey responses, most students had little to no comprehension of fluid power theory while some had an understanding of applications.

Following the nomenclature of Figure 9, student gains in understanding of fluid-power were calculated from the pre- and post-surveys. The pre-post comparison is shown in Figure 15 and the post-post comparison is shown in Figure 16. Pre-post and post-post comparisons result in different values but similar trends. From both comparisons, most students showed gains in understanding of fluid-power. As expected, students in Fluid Mechanics demonstrated larger gains in comprehension of hydraulic systems and students in Thermodynamics demonstrated larger gains in comprehension of pneumatic systems. However, both groups saw gains in both domains of fluid power.

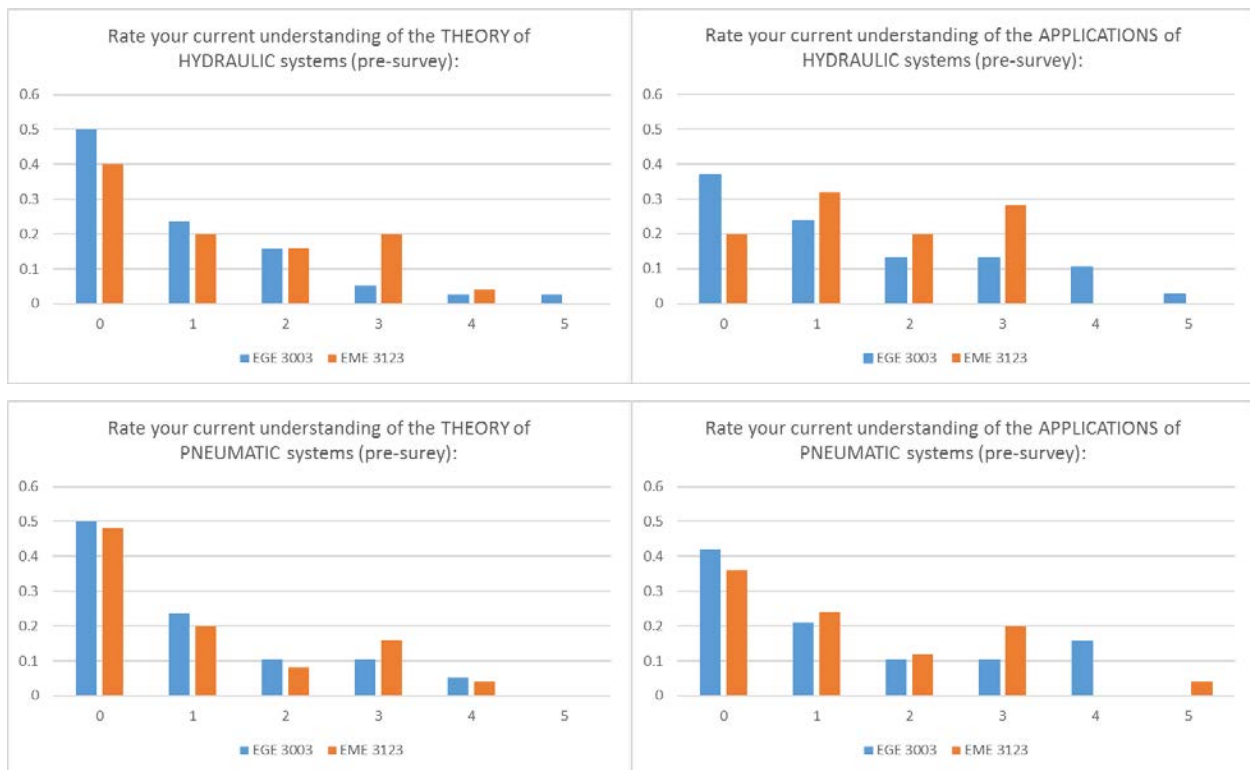

Figure 13 Normalized student self-assessment of fluid-power comprehension (pre-survey) on a range from 0 (none) to 5 (expert).

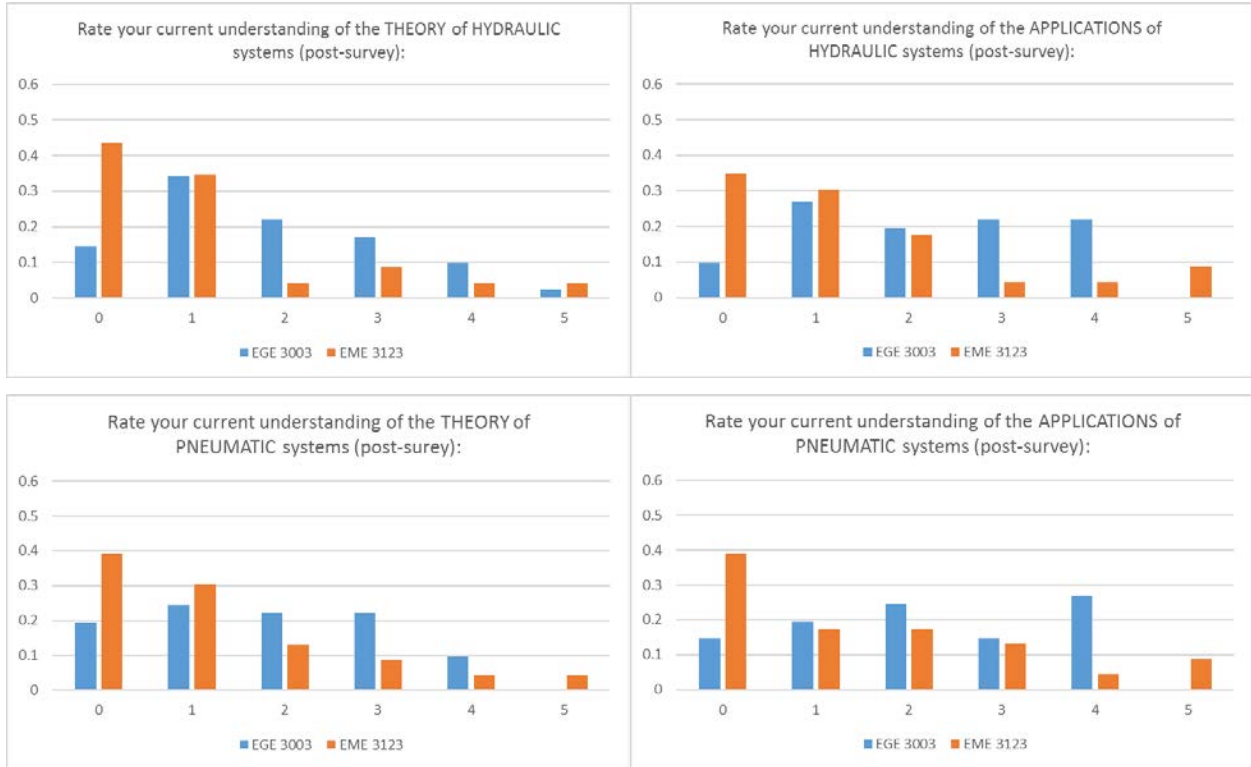

Figure 14 Normalized student self-assessment of fluid-power comprehension (post-survey) on a range from 0 (none) to 5 (expert).

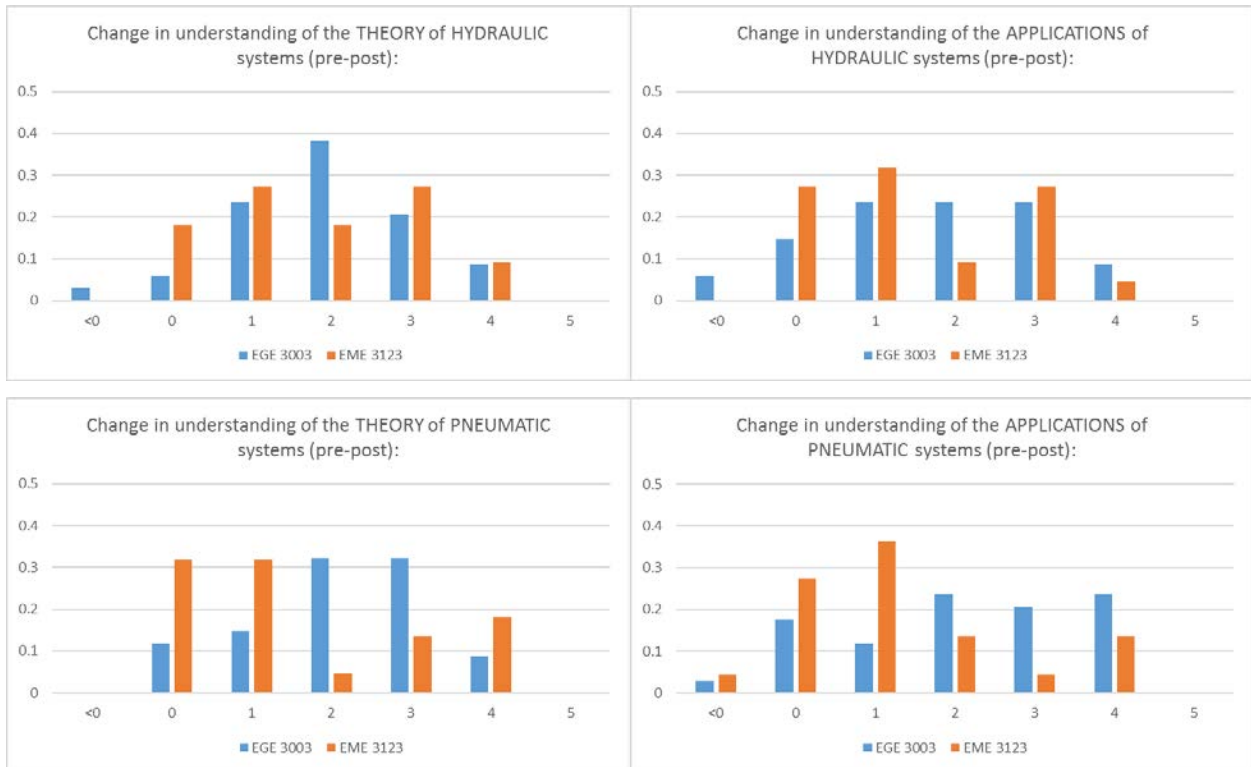

Figure 15 Pre-post comparison of student self-assessment of fluid-power comprehension.

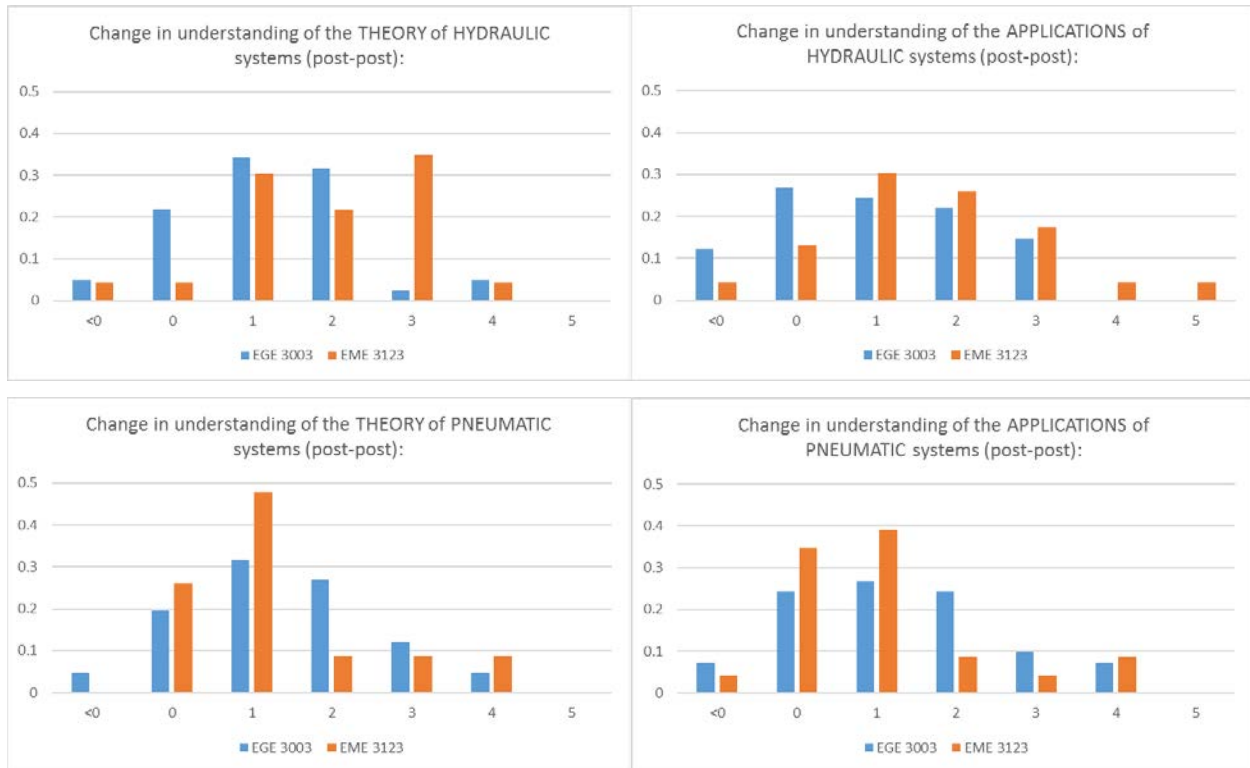

Figure 16 Post-post comparison of student self-assessment of fluid-power comprehension.

Conclusions

Collaborating with the National Fluid Power Association, faculty at Lawrence Tech incorporated fluid power based modules into the Mechanical Engineering curriculum. The works aims to teach students the basic theories and concepts in the area of fluid power and expose them to real-world hydraulic and pneumatic applications. The learning was accomplished by active learning and problem-based learning activities (mainly) outside of classroom due to the very compacted schedule. The modules were implemented in three consecutive semesters (Fall 2016, Spring 2017, Fall 2017). A total of eight faculty were involved and 239 students were impacted. Assessment results indicate that the modules helped students gain insight into the field of pneumatics and hydraulics, which is content not explicitly covered during class lectures. Student survey results also indicate that students perceive extensive practice in many aspects of entrepreneurial skills.

Acknowledgement

The authors gratefully acknowledge the National Fluid Power Association (NFPA) for sponsoring the presented work, and the support of fellow faculty members at Lawrence Tech for their willingness to use valuable class time in support of this work.

References

- [1] L. Liu, J. Mynderse, A. Gerhart and R. Fletcher, "Embedding Problem-Based Learning and Entrepreneurially Minded Learning into Fluid Mechanics and Thermodynamics Courses through Fluid Power Based Modules," in *Frontiers in Education Conference*, Indianapolis, 2017.
- [2] M. Prince, "Does Active Learning Work? A Review of the Research," *Journal of Engineering Education*, vol. 93, no. 3, pp. 223-231, 2004.
- [3] A. L. Gerhart and D. E. Melton, "Entrepreneurially Minded Learning: Incorporating Stakeholders, Discovery, Opportunity Identification, and Value Creation into Problem-based Learning Modules with Examples and Assessment Specific to Fluid Mechanics," *The Journal of Engineering Entrepreneurship*, vol. 8, no. 1, 2017.
- [4] C. J. Atman, S. D. Sheppard, J. Turns, R. S. Adams, L. N. Fleming, R. Stevens, R. A. Streveler, K. A. Smith, R. L. Miller, L. J. Leifer, K. Yasuhara and D. Lund, "ENABLING ENGINEERING: The Final Report for the Center for the Advancement of Engineering Education," 2010. [Online]. Available: <http://www.engr.washington.edu/caee/>.
- [5] T. A. Litzinger, L. R. Lattuca, R. G. Hadgraft and W. C. Newstetter, "Engineering Education and the Development of Expertise," *Journal of Engineering Education*, vol. 100, no. 1, pp. 123-150, 2011.
- [6] A. Yadav, D. Subedi, M. A. Lundeberg and C. F. Bunting, "Problem-based Learning: Influence on Students' Learning in an Electrical Engineering Course," *Journal of Engineering Education*, vol. 100, no. 2, pp. 253-280, 2011.
- [7] C. Hsieh and L. Knight, "Problem-Based Learning for Engineering Students: An Evidence-Based Comparative Study," *The Journal of Academic Librarianship*, vol. 34, no. 1, pp. 25-30, 2008.
- [8] M. J. Prince and R. M. Felder, "Inductive Teaching and Learning Methods: Definitions, Comparisons, and Research Bases," *Journal of Engineering Education*, vol. 95, no. 2, pp. 123-138, 2006.
- [9] D. W. Johnson, R. T. Johnson and K. A. Smith, "Cooperative Learning Returns To College What Evidence Is There That It Works?," *Change: The Magazine of Higher Learning*, vol. 30, no. 4, pp. 26-35, 1998.
- [10] M. Z. Jamaludin, K. Mohd. Yusof, N. F. Harun and S. A. H. S. Hassan, "Crafting Engineering Problems for Problem-Based Learning Curriculum," *Procedia - Social and Behavioral Sciences*, vol. 56, pp. 377-387, 2012.
- [11] D. Carpenter, K. Hayes, C. Ward and A. L. Gerhart, "Assessment and Evaluation of a Comprehensive Course Modification Plan," *The Journal of Engineering Entrepreneurship*, vol. 2, no. 2, 2011.
- [12] A. L. Gerhart and D. Carpenter, "Campus-wide Course Modification Program to Implement Active & Collaborative Learning and Problem-based Learning to Address the Entrepreneurial Mindset," in *Proc. 2013 ASEE Annual Conference and Exposition*, Atlanta, GA, 2013.
- [13] A. L. Gerhart and R. W. Fletcher, "Project-Based Learning and Design Experiences in Introduction to Engineering Courses: Assessing an Incremental Introduction of Engineering Skills," *Proc. 2011 ASEE Annual Conference & Exposition*, 2011.

- [14] A. L. Gerhart, D. D. Carpenter, R. W. Fletcher and E. G. Meyer, "Combining Discipline-specific Introduction to Engineering Courses into a Single Multidiscipline Course to Foster the Entrepreneurial Mindset with Entrepreneurially Minded Learning," *Proc. 2014 ASEE Annual Conference & Exposition*, 2014.
- [15] J. A. Mynderse, A. L. Gerhart, L. Liu and S. Arslan, "Multi-course Problem-based Learning Module Spanning Across the Junior and Senior Mechanical Engineering Curriculum: Mechatronics, Fluid Mechanic, and Heat Transfer," *Proc. 2015 ASEE Annual Conference & Exposition*, 2015.
- [16] L. Liu, J. A. Mynderse, A. L. Gerhart and S. Arslan, "Fostering the Entrepreneurial Mindset in the Junior and Senior Mechanical Engineering Curriculum with a Multi-Course Problem-based Learning Experience," *Proc. 45th IEEE Frontiers in Education Conference*, 2015.
- [17] E. G. Meyer and M. Nasir, "Fostering the Entrepreneurial Mindset Through the Development of Multidisciplinary Learning Modules Based on the "Quantified Self" Social Movement," *Proc. 2015 ASEE Annual Conference & Exposition*, 2015.
- [18] J. A. Mynderse and J. Shelton, "Assessment of an Improved Problem-Based Learning Implementation in a Senior/Graduate Mechatronic Design Course," *Proc. 2015 ASEE Annual Conference & Exposition*, June 2015.
- [19] J. A. Mynderse, J. N. Shelton and A. Gerhart, "Entrepreneurially Minded Learning in a Semester-Long Senior/Graduate Mechatronic Design Project," *Proc. of the ASME 2017 Dynamic Systems and Control Conference*, 2017.
- [20] Kern Entrepreneurial Engineering Network, "Entrepreneurial Mindset 101," [Online]. Available: <http://engineeringunleashed.com/keen/em101/>.
- [21] S. Condoor and M. McQuilling, "Incorporating An Entrepreneurial Mindset In Freshman Engineering Students," *Proc. 2009 ASEE Annual Conference & Exposition*, June 2009.
- [22] C. Kim and J. Tranquillo, "K-WIDE: Synthesizing the Entrepreneurial Mindset and Engineering Design," *Proc. 2014 ASEE Annual Conference & Exposition*, June 2014.
- [23] W. M. Jordan, C. C. Fry and K. W. V. Treuren, "Promoting the Entrepreneurial Mindset through Faculty Development," *Proc. 2016 ASEE Annual Conference & Exposition*, June 2016.
- [24] N. Duval-Couetil, J. Wheadon, E. Kisenwether and J. Tranquillo, "Entrepreneurship and ABET accreditation: How and where does it fit?," *Proc. 2013 IEEE Frontiers in Education Conference*, Oct 2013.

Appendix A: Assignment A in Thermodynamics

EGE3003 Fall 2017

HW “A” on Pneumatics Engineering – 30 points

Issued: September 11, 2017

Due: September 18, 2017

Introduction: The area of Pneumatics Engineering is an important one for many industries involved in manufacturing, production, or material conveyance. It falls under the larger classification of “Fluid Power”. In this assignment you will begin to learn about the area of Pneumatics Engineering and how it relates to our EGE 3003 Thermodynamics course.

1) Watch the following three videos. Then answer the questions after each.

<https://www.youtube.com/watch?v=fM11hGJnqtQ> (Youtube video titled “Introduction to pneumatics”)

- Describe in some detail the basic operations you see in this video that are powered by pneumatic systems, or compressed air. (2 points)
- List and discuss the advantages to pneumatic systems given in this video. (2 points)

<https://www.youtube.com/watch?v=0zIINr3Vqj4> (Youtube video titled “Pneumatic Desktop capping machine with printing function for semi-auto shampoo production line”)

- You may need to watch this video a few times to see what is happening. Describe in detail what is taking place. Why is this operation beneficial? Would this be better done by manual labor? Why, or why not? (2 points)

<https://www.youtube.com/watch?v=uRpxhIX4Ga0> (Youtube video titled “A car that runs on air”)

- The AirPod car is a vehicle powered by pneumatics (compressed air). Describe the history of using compressed air to provide power to move a vehicle. (2 points)
- What are the advantages to using a compressed air vehicle? Do you think it is practical? Why or why not? (2 points)

2) Describe the basic components that would be needed in producing, storing and delivering enough high-pressure air to power machines, production lines, or even vehicles. Go online to find references that can supplement and justify your answers. List and describe these references. (5 points)

3) In chapter 3 of our Thermodynamics textbook we are learning about the nature of gases and the issues they face when compressed to high pressures. Review all of sections 3.11 and 3.12.

- Describe the issues that are presented in these sections relating to compressed gases. (2 points)
- How would a thorough understanding of these topics be beneficial in pneumatics engineering applications and systems? Why? Elaborate upon your answer in detail. (2 points)

4) The area of pneumatics engineering falls under the larger umbrella of Fluid Power. This area is so important in industry that there is a professional organization devoted to assisting and supporting engineers and manufacturing system designers in using fluid power. This organization is the National Fluid Power Association (NFPA). Their website is located at:

<http://www.nfpa.com/>

- Go to their website and review the various sections of their website. Describe what the NFPA sees as their mission. (2 points)
- Under the “What is Fluid Power?”, they discuss several topics. Briefly describe these various topics. (2 points)
- How they define pneumatics? (2 points)
- They also give an example of how “a fluid pressure of 1,000 psi can push with 3140 lbs. of force. A pneumatic cylinder using 100 psi air would need a bore (diameter) of approximately 6½ in. to develop the same force.” Quantitatively (by calculations) show how this is so. (2 points)
- Go to the “Fluid Power Education & Careers” section on the upper heading of website. Under the “Students” section review, list and describe in five or six sentences each three different types of job positions and the associated responsibilities. In addition pick three companies and describe how they may use pneumatics. (3 points)

Appendix B: Assignment B in Thermodynamics

EGE3003 Fall 2017

HW “B” on Pneumatics Engineering – 25 points

Issued: October XX, 2017

Due: October XX, 2017

Background: The area of Pneumatics Engineering is an important one for many industries involved in manufacturing, production, or material conveyance. It falls under the larger classification of “Fluid Power”. In this assignment you will learn about typical operation pressures of pneumatics systems and their relationship to ideal gas assumptions.

1) Most industrial pneumatic systems operate using standard 100 psig compressed air (available in most industrial operations). Watch the following Youtube video to understand some basics of pneumatic air compressors:

“How to Choose and Use an Air Compressor - This Old House” at www.youtube.com/watch?v=u6zddqNIIdFs

2) Two engineers are discussing if typical 100 psig compressed air used in a pneumatic driven and controlled manufacturing operation can be considered an ideal gas and, therefore, allows them to use the ideal gas law. You can assist them by referencing the compressibility factor “Z”. Use the compressibility factor Z and the information from Figure A-1 (of our course textbook) to quantitatively and computationally justify if the 100 psig shop air can, or cannot, be considered an ideal gas. (Recall that for many applications values of “Z” within the range of 0.97 to 1.03 could easily allow the use of the ideal gas law with few problems and little error.) (5 points)

2) A piston-cylinder system has the following configuration. A piston has an outer diameter of 5 cm, and slides freely within a cylinder with the same inner diameter. The cylinder is fully sealed and closed at one end and the other end is open, allowing for the movement of the piston. Initially the piston is located 1 meter from the closed end of the cylinder. Initially conditions of the air are:

$$T_1 = 26^\circ\text{C}$$

$$P_1 = 1 \text{ atmosphere}$$

a) At these initial conditions it is reasonable to use the ideal gas law. The piston, however, is then very rapidly pressed into the cylinder. No air leaves the piston-cylinder assembly. The piston is pressed quickly into the cylinder (within a fraction of a second) and locked into place. The piston movement is so rapid that the air/system can initially be assumed to be adiabatic. At this new piston position, the air temperature within the cylinder correspondingly and momentarily rises to 550°C and the air pressure increases to 100 atmospheres. At the instant of the new piston position is it still reasonable to assume the air in the cylinder is an ideal gas? Quantitatively and computationally verify this using “Z” from Figure A-2. (8 points)

b) Compute the work that was rapidly applied to the piston to move it to the new position within the cylinder. (7 points)

c) The piston and cylinder are left at the new piston position remains locked into place, and left to sit for several hours such that the temperature of the gas and the cylinder are allowed to return to the initial temperature of 26°C, but the piston does not move from the new position. Determine the pressure of the air within the cylinder under these conditions. (5 points)

EME 3123 – Fluid Mechanics – Design Project

Fountain from Youth
(a.k.a. Bellagio's Little Cousin)
Spring 2017, Section 1, Dr. Gerhart

Assigned: Thursday, March 16

Preliminary Reply: Monday, March 27

Interim Design Review Due: Monday, April 10

Final Design Due: Monday, April 24

Instructions:

You must work in a team of three of your choosing. Submit one report for the entire team. The Preliminary Reply is a list of responses by the team concerning preliminary problem solving. For the Interim Design Review, I will carefully inspect your work and make comments to improve your design and process. Then you will have time to work-out any problems or issues, fix mistakes, or alter your design. This should allow you the chance to develop a very good and practical design (assuming that you have substantial work attempted for the Interim Design). The Interim Design does not need to be typed and formal, but have it very neat so that I can clearly inspect your work. Your final design report will be typed with the format indicated below. Sample calculations can be done by hand in the appendix, but your calculation/design steps with some equations should be in the main body of the report. I also want your design explained well and readable (i.e., pay attention to presentation, clarity, and grammar). Since a design report is not the same as a homework assignment, don't just do some calculations with a few numbers in boxes. Explain your steps and show all of your work neatly. A good design with sloppiness and poor explanation will appear like a bad design. I do grade grammar and clarity.

Format:

Abstract – This section is one paragraph or two short paragraphs that briefly describes the main components of your design. It should be a stand-alone section that reveals the major conclusions that are of interest to your customer.

Introduction – Describe the problem to be solved, objectives/goals, assumptions.

Description – Include a comprehensive schematic(s) of your final design near the beginning of this section. Then go through the design process with important calculated results and/or graphs, tables, etc. and include additional sketches and drawings if necessary. Be logical in your sequence of this section. Always title (caption) and label any figures. As common practice, any figure in the report must be discussed somewhere in the text.

Conclusion – Summarize the features of your design, the estimated cost to produce it, and the estimated yearly operational cost.

References – Use a standard format for references (e.g., APA, MLA, Chicago)

Appendix – This section is not required, but may include useful items that add detail which was not completely necessary in main body of the report. Examples include hand calculations, lengthy computer print-outs, or anything else that supports your design. Everything in the Appendix should be noted in the report. For example, "Appendix A shows the detailed calculations of the previous result." Otherwise, the material does not belong in the Appendix and hence the report.

Fountain with Hydraulically Controlled Nozzle System

Three and half years ago, your rich uncle, Mortimer, purchased a large tract of land in the Upper Peninsula of Michigan. He did not become wealthy by purchasing worthless things, yet the land he bought has no valuable minerals, nor any profit from lumber. Instead, it has a magnificent wilderness resort lodge, which had been abandoned years ago and had fallen into a dilapidated state. The lodge is known as the Overlook Hotel. (No, not *that* Overlook Hotel from *The Shining*; that place makes people go crazy and is located in

the mountains of Colorado.) After Uncle Mortimer restored the Overlook, his guests come to enjoy forest hiking, mountain biking, and a variety of other outdoor pursuits. Some just come to enjoy the peace and quiet at the hotel. Since the Overlook is located on a rocky hillside 300 vertical feet above the lake (which is what the hotel “overlooks”) and 2200 ground feet from the lake’s edge, he installed a chair lift for downhill skiing to draw customers during the brutally cold winter months. He has also installed a surface called “Snowflex” so that skiers can enjoy the slopes in both summer and winter. Yet with all that, there is one more element that Uncle Mort feels would really enhance his hotel: a mesmerizing fountain display. He has seen the fabulous Bellagio Fountains, and enjoys the interesting fountain in the McNamara Terminal of the Detroit Metropolitan Airport. He wants something that will be appropriate for his wilderness resort.

After learning of your vast new knowledge of fluid mechanics, he has asked you to design a fountain. As a member of the National Fluid Power Association, Uncle Mort requires that one or more of the nozzles is controlled by a hydraulic system which will allow the nozzle(s) to move the water jet(s) in some sort of pattern. The water jet(s) from the movable nozzle(s) must be high enough pressure to allow for a sufficient water height. He wants this fountain to be an attraction for his customers. You will need to consider a water delivery system, filter(s), a piping system, hydraulic system, and other components for this fountain. You must keep in mind that Uncle Mortimer is miserly with his expenses; he did not get rich by wasting money. But Uncle Mortimer is very generous with his family. Therefore if you can design an efficient and cost effective system, you will not only be paid well, you will likely inherit the land and hotel in Uncle Mortimer’s will!

Preliminary Reply Investigation: some (not all) considerations during the first ten days. If necessary, consult your customer.

- What major components are needed for a fountain and a hydraulically controlled device?
- Where will the fountain be located?
- What should be the overall footprint size of the fountain?
- When and/or how often is the fountain operational?
- What intriguing display features should the fountain exhibit, and how many nozzles does that require? How many of those nozzles are hydraulically controlled?
- What items have a significant cost for operation?

Some considerations:

- Ensure that the fountain has sufficient water flow and pressure.
- Be careful with pipe selection (sizing) and material, ensuring that the water is fairly equally distributed throughout the area based on the display options. Carefully consider the layout of the water system so as not to overcomplicate the problem.
- Be cautious that the components and design are not too costly. You should keep track of approximate expenses for components, and keep notes of how you kept costs down. Uncle Mort will want to know. You do not need to consider installation costs, unless your design plan is especially unique. (Consult your customer to determine if installation costs are required for your plan.)
- Include operational expenses for Uncle Mortimer. In other words, choose your water delivery system wisely. What will it cost per year to run the water operation?
- You are designing the fluid system and hydraulic system only, not any potential electronic control system, and not the solid structure of the pool, pipe/pump support, etc. On the other hand, you must consider forces from the nozzles (as per the hydraulic system requirements). You will also have to consider placement of the various components and, of course, sizes.
- Be careful with all fluid components sizing (pipes, pumps, etc.). Do not drastically oversize or undersize your pump(s).
- Valves....
- The hillside continues above the lodge another 400 vertical feet to the summit in 600 ground feet.

Appendix H: Suggested Class Demonstration Kits

Festo Pneumatics Starter

<http://www.festo-didactic.com/int-en/learning-systems/mechatronics-and-factory-automation/meclab/hardware/pneumatics-starter.htm?fbid=aW50LmVuLjU1Ny4xNy4xOC4xMTE5Ljc4Nzk>

Principles of Hydraulics—Student Laboratory Kit

<https://www.flinnsci.com/principles-of-hydraulics---student-laboratory-kit/ap6494/>

Hydraulic Hot Water Bottle—Multi-Demonstration Kit

<https://www.flinnsci.com/hydraulic-hot-water-bottle---multi-demonstration-kit/ap6857/#variantDetails>

Hydraulic Elevator - Physical Science Demonstration Kit

<https://www.flinnsci.com/hydraulic-elevator---physical-science-demonstration-kit/ap7447/>

Equilibrium Tubes Apparatus For Physics:

https://www.amazon.com/gp/product/B0088AQZXK/ref=ox_sc_act_title_1?smid=A37SSOMGWCKVU1&psc=1

Ideal gas law Apparatus:

https://www.amazon.com/SEOH-Gas-Law-Apparatus-Advanced/dp/B00KI2CNS2/ref=sr_1_2?ie=UTF8&qid=1509983439&sr=8-2&keywords=gas+law+apparatus&dpID=41IeBYNCEoL&preST=_SX342_QL70_&dpSrc=srch

Thermodynamics: thermodynamic hand boiler:

https://www.amazon.com/Hand-Boiler-Pack-understanding-thermodynamic/dp/B00AL5F30Q/ref=sr_1_3?ie=UTF8&qid=1509984122&sr=8-3&keywords=Thermodynamic+Hand+Boiler&dpID=41ttIegMX4L&preST=_SX300_QL70_&dpSrc=srch

Air pressure demonstration:

Venturi Tube:

https://www.amazon.com/GSC-International-2201-Venturi-Tube/dp/B01L9OYBZK/ref=sr_1_3?s=industrial&ie=UTF8&qid=1511216261&sr=1-3&keywords=Venturi+Tube&dpID=31Fz14pWdML&preST=_SY445_QL70_&dpSrc=srch